

# FORCE USA

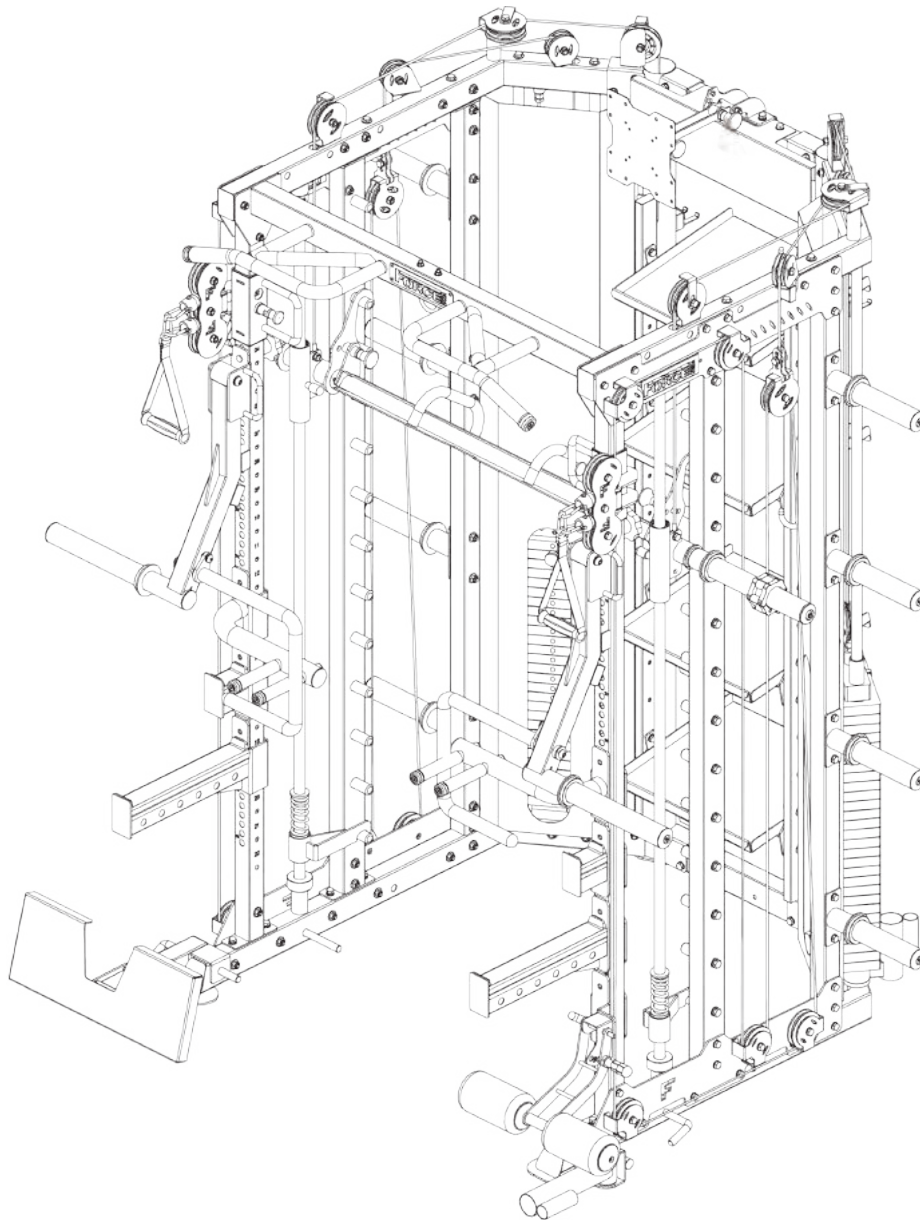

OWNERS MANUAL | **F-G15**



# ASSEMBLY MANUAL

## BEFORE YOU START

Read all instructions in this manual before assembling or using this equipment.

Remove all parts from the packaging and separate and count each various component to ensure everything has been correctly provided.

Follow the instructions and consult both the individual assembly pages and the overall expanded views of the equipment.

It is the owner's responsibility to ensure that all users of this unit have read the owner's manual and are familiar with the safety precautions.

We recommended you keep these instructions.

## SAFETY PRECAUTIONS

- Highly recommended for two or more people to assemble the equipment
- Assemble equipment on a flat surface
- Consider placing a mat under equipment to protect your floor
- Only tighten nuts and bolts by hand until whole equipment is assembled
- Ensure all parts are in working order prior to use
- Do not use equipment outdoors or around water
- Keep hair, fingers and clothing away from moving parts
- Only use attachments recommended by the manufacturer
- Never operate if parts are not functioning correctly
- Always stretch prior to using equipment
- Stop immediately if you experience any pain, dizziness or nausea.
- Before starting any exercise program consult your doctor

# **IMPORTANT ASSEMBLY INFORMATION**

NOTE: It is strongly recommended that this equipment is assembled by two or more people to avoid possible injury.

## **FASTENING NUTS AND BOLTS**

- Only tighten all nuts and bolts after all components have been fully assembled.
- Do not over tighten any component with pivoting function.
- Make sure all pivoting components are able to move freely.

Place all parts in a cleared area and remove the packing materials. Do not dispose of the packing materials until you complete all assembly steps.

PLEASE NOTE: Descriptions of pieces as LEFT and RIGHT are from the point of view of standing behind the equipment facing towards the front.

# TABLE OF CONTENTS

Parts list .....	3-8
Assembly step 1 .....	9-11
Assembly step 2 .....	12-15
Assembly step 3 .....	16-19
Assembly step 4 .....	20-23
Assembly step 5 .....	24-27
Assembly step 6 .....	28-30
Assembly step 7 .....	31-33
Assembly step 8 .....	34-35
Assembly step 9 .....	36-38
Assembly step 10 .....	39-41
Assembly step 11 .....	42-46
Assembly step 12 .....	47-49
Assembly step 13 .....	50-51
Spare part .....	52
Upgrade Drawing.....	53-65

# PART IDENTIFICATION

Use the drawing below to identify small parts used in assembly.

IMPORTANT: if you cannot find a part in the hard ware kit, check to see if it has been reassembled.

Extra hardware may be included.



01 Back Left Upright Frame 1PC



02 Back Link Frame 1PC



03 Back Left Upright Frame 1PC



04 Back Upper Link Frame 1PC

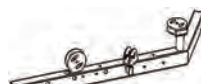

08 Right Upper Frame 1PC



09 Left Upper Frame 1PC



10 Right Ground Frame 1PC



11 Left Ground Frame 1PC



12 Left Middle Upright Frame 1PC



13 Right Middle Upright Frame 1PC



18 Guide Tube 1PC



19 Upright Frame 2PC

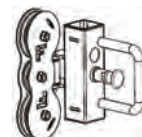

20 Sliding Frame Left 1PC



21 Sliding Frame Right 1PC



22 Guide Tube Right 1PC



23 Down Pulley Cover Left 1PC

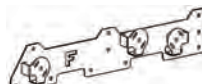

24 Down Pulley Cover Right 1PC

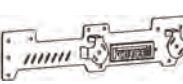

25 Up Pulley Cover Left 1PC

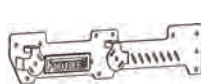

26 Up Pulley Cover Right 1PC



27 Chin Up Frame 1PC



29 Selector Rod 2PC



30 Pin 2PC



31 Weight Group 2PC



32 Pulley Bracket 2PC



33 Guide Rod 4PC



34 Rubber Block 4PC



35 Pin 2PC



37 Pulley Ø95 16PC



38 Pulley Ø75 4PC



39 Pulley Frame 2PC

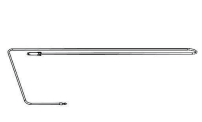

40 Cable 2PC



41 Cable 2PC

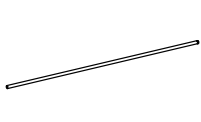

43 Guide Rod 2PC

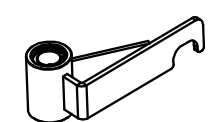

44 Safety Hook Right 1PC

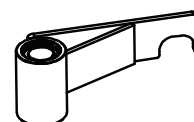

45 Safety Hook Left 1PC

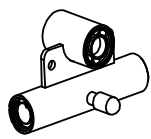

46 Sliding Sleeve 2PC



47 Barbell Rod 1PC



48 Barbell Plate Holder 2PC

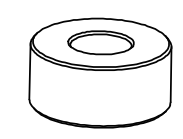

52 Rubber Block 2PC

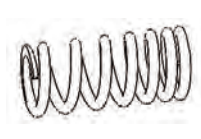

53 Spring 2PC

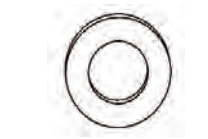

54 Barbell Plate holder Ring 4PC

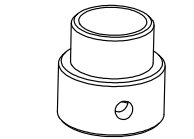

55 Guide Rod Fixing Sleeve 2PC

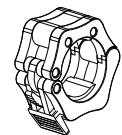

57 Barbell Rod Collar 6PC

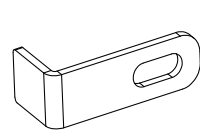

58 Plastic Strip 6PC

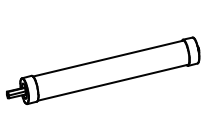

60 Weight 2PC



61 Cable 2PC

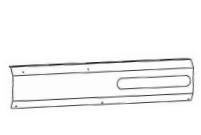

62 Weight Plate Cover Left 2PC

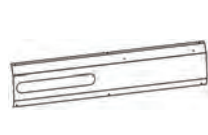

63 Weight Plate Cover Right 2PC

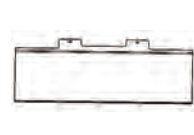

64 Logo Board 1PC



67 Hook 4PC

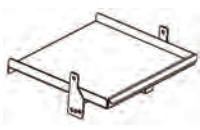

68 Shelf Frame 2PC



69 Shelf 2PC

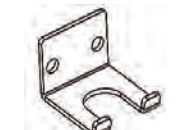

70 Hook 4PC

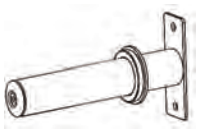

73 Barbell Plate Holder 8PC

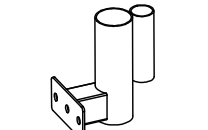

74 Barbell Rod Cup 2PC

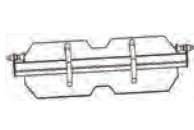

76 Leg Press Plate 1PC

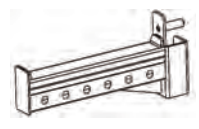

77 Long Barbell Rod Holder Right 1PC

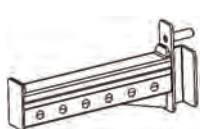

78 Long Barbell Rod Holder Left 1PC

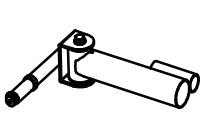

79 Spinning Barbell Rod Cup 1PC

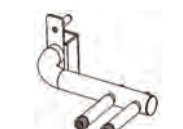

80 Dip Bar Right 1PC



81 Dip Bar Left 1PC

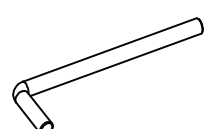

82 L Shape Pin 4PC

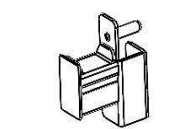

83 Short Barbell Rod Holder Right 1PC



84 Short Barbell Rod Holder Left 1PC



85 Selector Part 1PC



86 Leg Curl Frame 1PC

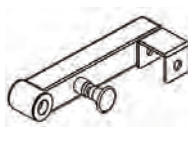

87 Link Frame 1PC

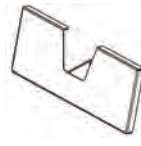

88 Foot Plate 1PC

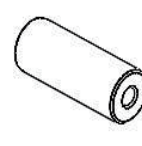

89 Internal Thread Shaft 1PC

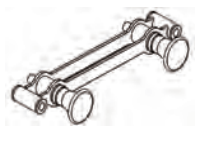

90 Link Frame 1PC

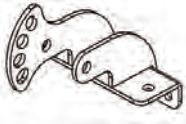

91 Selector Frame 1PC



92 Shaft 2PC



93 TV Bracket 1PC



95 Hand Hold 2PC



96 Push Frame Left 1PC

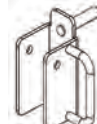

97 Link Part 2PC



98 Handle Left 1PC

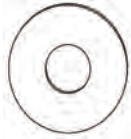

100 Washer 2PC

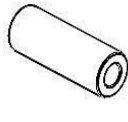

105 Internal Thread Shaft 2PC



106 Lock Knob 2PC



108 Push Arm Right 1PC

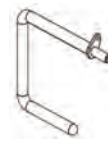

109 Handle Right 1PC

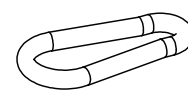

110 Snap Hook 1PC



111 Curved Bar 1PC

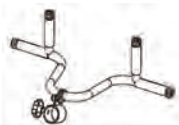

112 Lift Device 1PC



113 Snap Hook With Chain 4PCS



114 Ship Bar 1PCS



115 Long Bar 1PCS



116 Handle 2PC



117 Short Bar 1PC

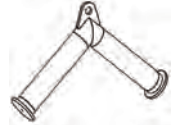

118 V Bar 1PC



119 Triangle Handle 1PC

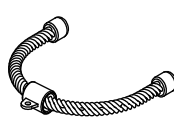

120 Triceps Rope 1PC

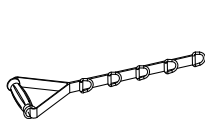

121 Handle Belt 2PC

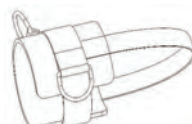

198 Ankle Strap 1PC

# HARDWARE IDENTIFIER

Note. The following parts are not drawn to scale, Please use your own ruler to measure the size.

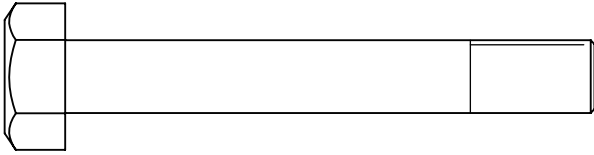

**M10\*70 52PCS**

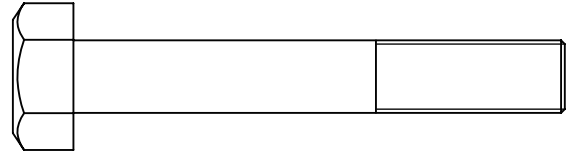

**M10\*65 4PCS**

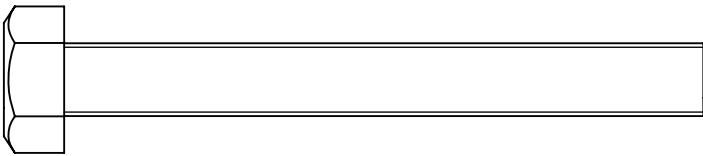

**M10\*85 2PCS**



**M8\*10 4PCS**

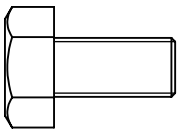

**M8\*16 8PCS**

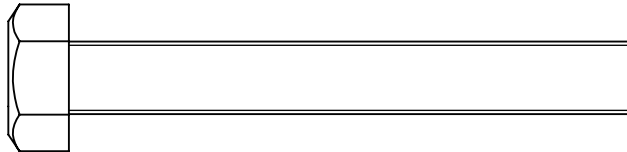

**M10\*75 22PCS**

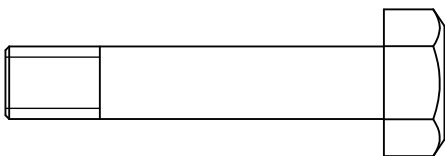

**M10\*50 6PCS**

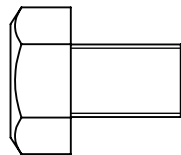

**M10\*16 12PCS**

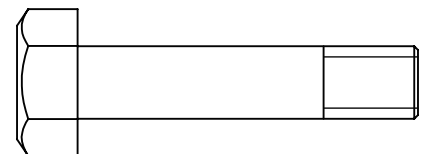

**M10\*45 14PCS**

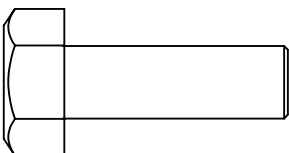

**M10\*25 12PCS**

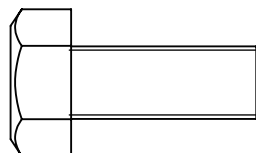

**M10\*30 2PCS**

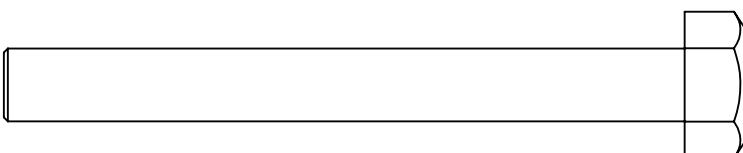

**M10\*90 8PCS**

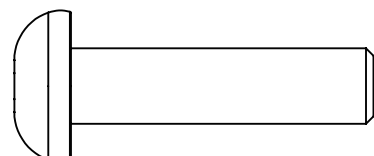

**M12\*40 2PCS**



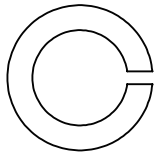

$\phi$  12 2PCS

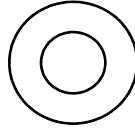

$\phi$  8 8PCS

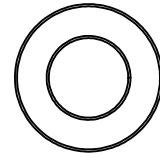

$\phi$  10 166PCS

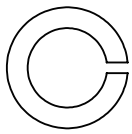

$\phi$  10 22PCS

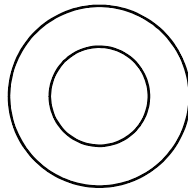

$\phi$  12 2PCS

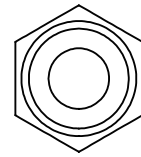

M10 98PCS

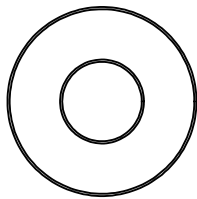

$\phi$  25\* $\phi$  10\*2 66PCS

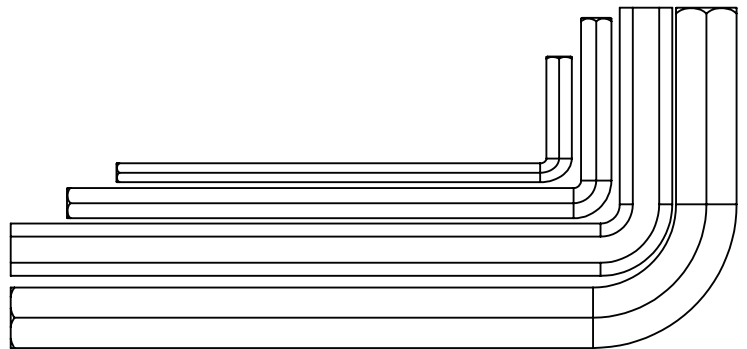

3、4、6、8MM 1PCS

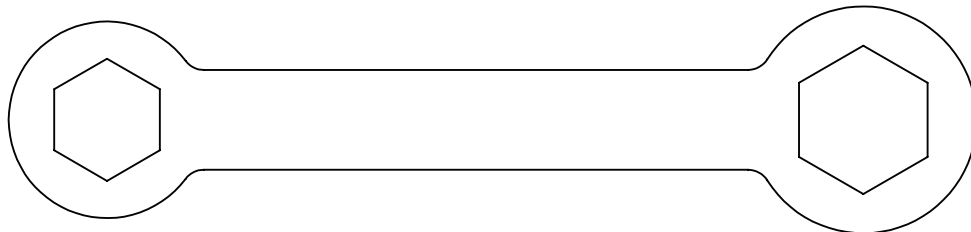

14-17 1PCS

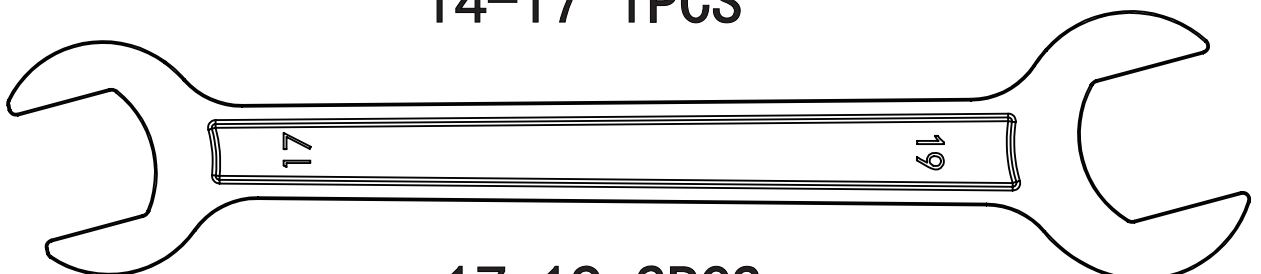

17-19 2PCS

# PARTS LIST

No.	Description	Note	Qty.
1	back left upright frame		1
2	back link frame	□50x70x2	1
3	back right upright frame		1
4	back upper link frame		1
5	hexagon bolt	M10x75	22
6	lock nut	M10	128
7	washer	Φ10	246
8	right upper frame		1
9	left upper frame		1
10	right ground frame		1
11	left ground frame		1
12	left middle upright frame		1
13	right middle upright frame		1
14	spring washer	Φ10	42
15	hexagon bolt	M10x25	16
16	hexagon bolt	M10x90	8
17	big washer	Φ25xΦ10x2	66
18	guide tube		1
19	upright frame		2
20	sliding frame left		1
21	sliding frame right		1
22	guide tube right		1
23	down pulley cover left		1
24	down pulley cover right		1
25	up pulley cover left		1
26	up pulley cover right		1
27	chin up frame		1
28	hexagon bolt	M10x70	52
29	selector rod	Φ25x798	2
30	pin	10x60	2
31	weight group	28+1(130KG)	2
32	pulley bracket		2
33	guide rod		4
34	rubber block	Φ60xΦ27x42	4

# PARTS LIST

No.	Description	Note	Qty.
35	pin	Φ10x100	2
36	hexagon bolt	M10x45	40
37	pulley	Φ92	24
38	pulley	Φ75	4
39	pulley frame		2
40	cable		2
41	cable		2
42	hexagon bolt	M10x30	2
43	guide rod	Φ25x1922	2
44	safety hook right		1
45	safety hook left		1
46	sliding sleeve		2
47	barbell rod		1
48	barbell plate holder		2
49	allen bolt	M12x40	2
50	spring washer	Φ12	40
51	washer	Φ12	40
52	rubber block	Φ60xΦ26x25	2
53	spring	Φ6x102	2
54	barbell plate holder ring	Φ45xΦ25.5x5	4
55	guide rod fixing sleeve	Φ40xΦ25.5x35	2
56	screw	M8x10	2
57	barbell rod collar	Φ85xΦ50xH49	6
58	plastic strip		6
59	hexagon bolt	M10x50	6
60	weight		2
61	cable		2
62	weight plate cover left		1
63	weight plate cover right		1
64	logo board		1
65	hexagon bolt	M10x16	12
66	hexagon bolt	M10x85	2
67	hook		4
68	shelf frame		2

# PARTS LIST

No.	Description	Note	Qty.
69	shelf		4
70	hook		4
71	washer	Φ8	16
72	hexagon bolt	M8x16	8
73	barbell plate holder		8
74	barbell rod cup		2
75	hexagon bolt	M10x65	4
76	leg press plate		1
77	long barbell rod holder right		1
78	long barbell rod holder left		1
79	spinning barbell rod cup		1
80	dip bar right		1
81	dip bar left		1
82	L shape pin	Φ17x250x77L	4
83	short barbell rod holder right		1
84	short barbell rod holder left		1
85	selector part		1
86	leg curl frame		1
87	link frame		1
88	footplate		1
89	internal thread shaft	Φ25x67-M10	1
90	link frame		1
91	selector frame		1
92	shaft	Φ10x85xM10	2
93	TV bracket		1
94	hexagon bolt	M10x20	10
95	hand hold		2
96	push frame left		1
97	link part		2
98	handle left		1
99	allen bolt	M10x20	2
100	washer	Φ33xΦ12.5xT3	2
101	allen bolt	M12x25	6
105	internal thread shaft	Φ20x56.5-M12	2

# PARTS LIST

No.	Description	Note	Qty.
106	lock knob	M16	2
108	push arm right		1
109	handle right		1
110	snap hook		6
111	curved bar		1
112	lift device		1
113	snap hook with chain		4
114	ship bar		1
115	long bar		1
116	handle		2
117	short bar		1
118	V bar		1
119	triangle handle		1
120	triceps rope		1
121	handle belt		2
122	lock nut	M10	8
123	plug	□40x20x1.5	6
124	square plug	50x70x2	2
125	barbell holder	Φ25xM12x98	28
126	hexagon bolt	M12x25	32
127	tube handle left		1
128	plug	50-60	4
129	pin	M20x1.5-Φ10	3
130	pulley bracket		2
131	pulley	Φ60	2
132	internal thread shaft	Φ19.8x49.5	2
133	powder metallurgy sleeve	Φ33xΦ29xΦ20x18	4
134	tube handle right		1
135	U hook		1
136	lock nut	M8	6
137	round plug	Φ32x1.5	4
138	handle cover	Φ38xΦ32x130	2
139	ring	Φ38x32x25	2
140	screw	M10x25	2

# PARTS LIST

No.	Description	Note	Qty.
141	insert nut	Φ29.3-M10	2
142	logo plate		1
143	hollow rivet	4x8	8
144	logo plate		2
145	lock nut	M12	2
146	insert nut	Φ23-M10-4F	8
147	cable end		4
148	screw	M5x25	4
149	cable ball		4
150	bearing	Φ40xΦ25x58	6
151	bearing ring		8
152	plastic cover		2
153	bearing	6005	4
154	barbell rod cover	Φ30xΦ25.1x1056	1
155	screw	M6x16	4
156	barbell rod hook right		1
157	barbell inside rod	Φ25x1975	1
158	spring washer	Φ6	4
159	barbell rod hook left		1
160	ring	Φ60x27	2
161	end cap	Φ50x37	2
162	rubber ring	Φ70xΦ50xΦ10	12
163	tube	Φ49.5x0.6	4
164	hook cover	Φ8x100	4
165	plug	□25x50x1.5	4
166	tube	Φ49.6x0.6x200	8
167	end cap	Φ11xΦ18xΦ42xΦ50	10
168	allen bolt	M10x25	10
169	pin	Φ12xM20x40	4
170	rubber cover long	387	2
171	rubber cover short	85	1
172	plug	Φ25x2	5
173	plug	Φ48x2.5	4
174	ring	Φ31.5xΦ25.5	4

# PARTS LIST

No.	Description	Note	Qty.
175	screw	M8x20	4
176	insert nut	Φ23-M8	6
177	handle cover	Φ25x125	4
178	lock pin	M18x12xΦ10	1
179	foam	Φ25xΦ100x175	2
180	foam inner cover	Φ65xΦ25x12	2
181	foam outer cover	Φ65xΦ9x13	2
182	allen bolt	M8x25	2
183	T pin	Φ10x100	1
184	link part		1
185	sleeve	Φ50xΦ47xΦ25x15	4
186	barbell rod cup		1
187	internal thread shaft	Φ25x77xM12	1
188	tube	Φ25x86	1
189	shaft	Φ22x39.5	1
190	ring	Φ25xΦ20x5	1
191	plug	□50x50x2	1
192	pin	Φ12xM20x75	1
193	sleeve	Φ20xΦ16xΦ10.5x15	4
194	square rubber block	□50x50x30	4
195	allen bolt	M10x35	4
196	6004bearing		4
197	handle cover	Φ32xΦ24.8x830	2
198	ankle strap		1



# ASSEMBLY STEP 1

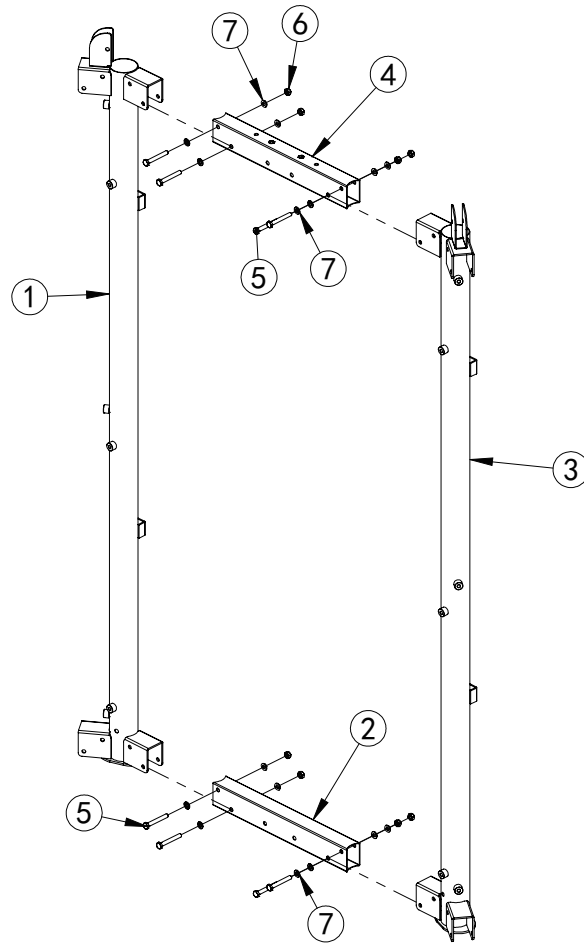

No.	Description	Note	Qty.
1	back left upright frame		1
2	back link frame	□50x70x2	1
3	back right upright frame		1
4	back upper link frame		1
5	hexagon bolt	M10x75	8
6	lock nut	M10	8
7	washer	Φ10	16



# ASSEMBLY DRAWING

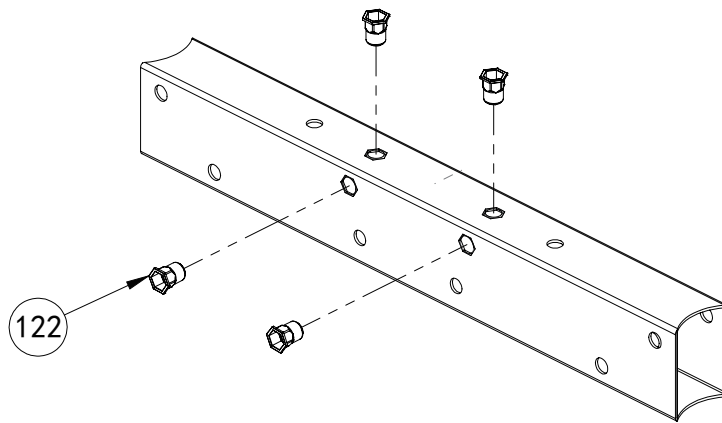

back upper link frame  
1pcs/set

# ASSEMBLY DRAWING

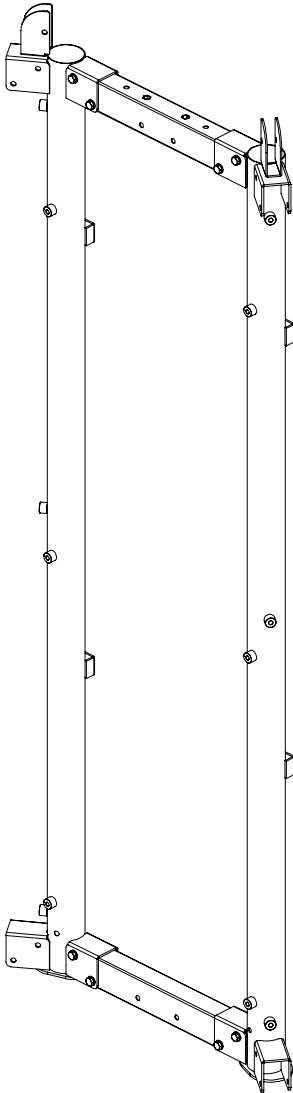

1 Fix back left upright frame-1, back right upright frame-3, back link frame-2 and back upper link frame-4 use M10x75 hexagon bolt-5,  $\Phi 10$  washer-7 and M10 lock nut-6

## ASSEMBLY STEP 2

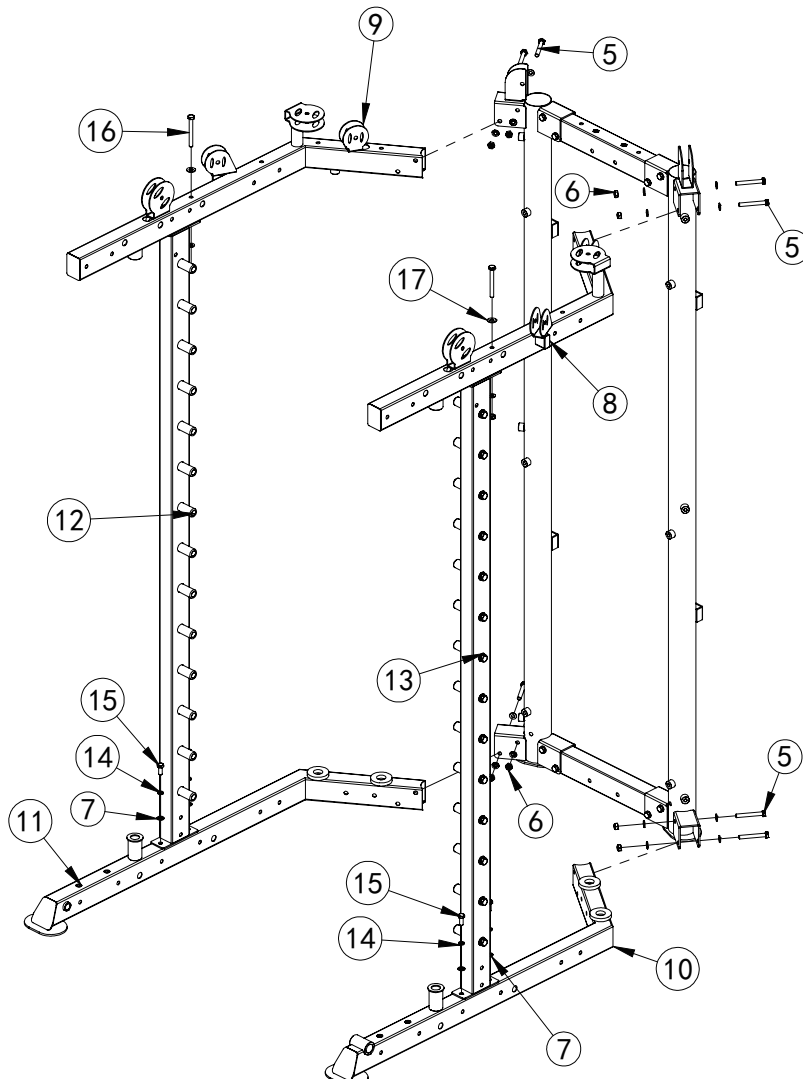

No.	Description	Note	Qty.
8	right upper frame		1
9	left upper frame		1
10	right ground frame		1
11	left ground frame		1
12	left middle upright frame		1
13	right middle upright frame		1
5	hexagon bolt	M10x75	8
6	lock nut	M10	10
7	washer	Φ10	22
14	spring washer	Φ10	4
15	hexagon bolt	M10x25	4
16	hexagon bolt	M10x90	2
17	big washer	Φ25xΦ10x2	2

# ASSEMBLY DRAWING

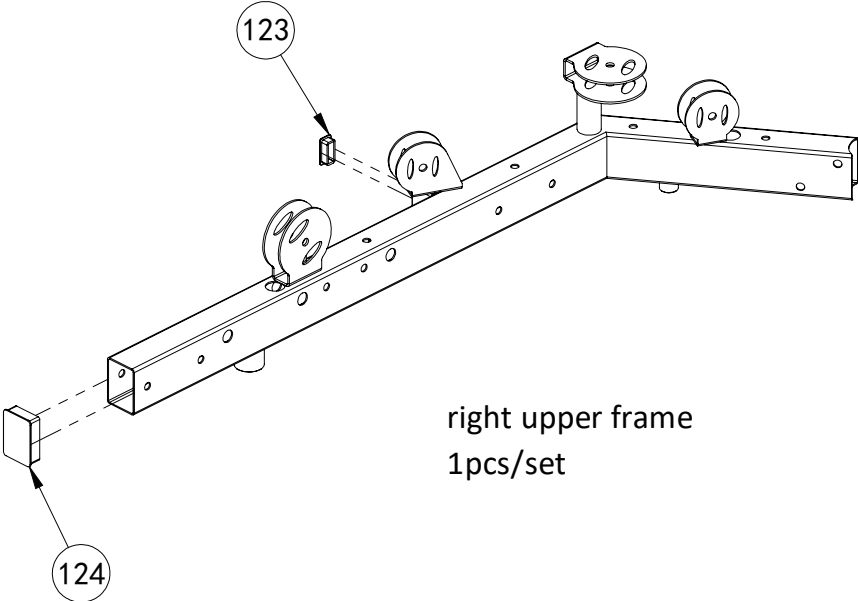

right upper frame  
1pcs/set

No.	Description	Note	Qty.
123	plug	□40x20x1.5	1
124	square plug	50x70x2	1

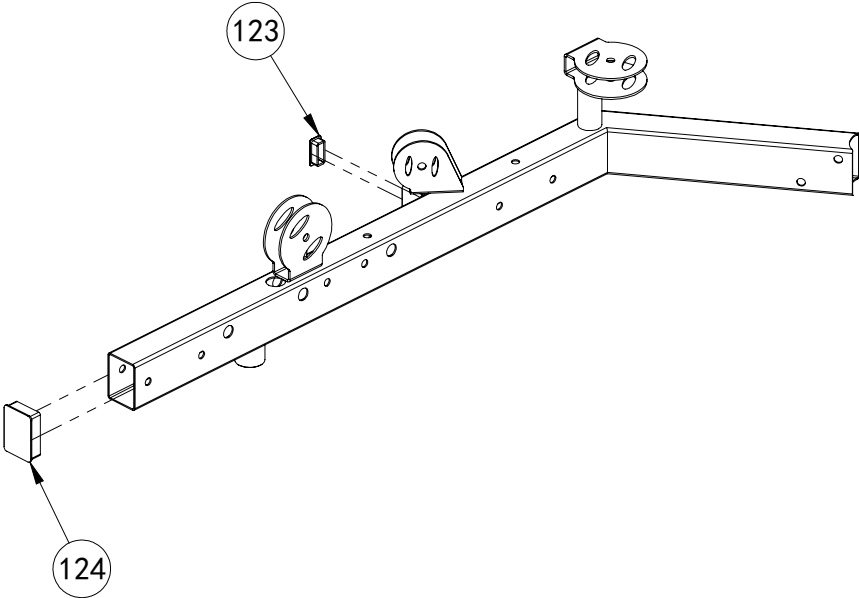

No.	Description	Note	Qty.
123	plug	□40x20x1.5	1
124	square plug	50x70x2	1

left upper frame  
1pcs/set

# ASSEMBLY DRAWING

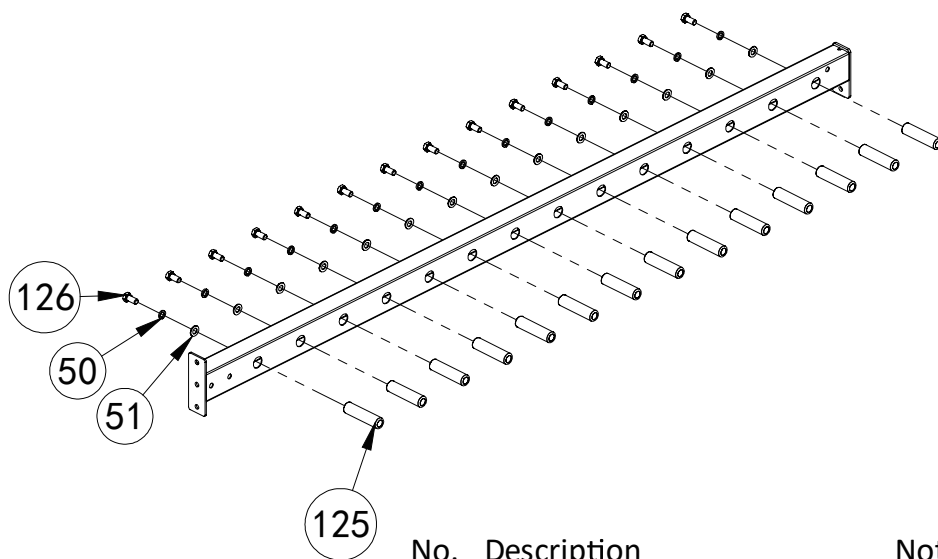

left middle upright frame  
1pcs/set

No.	Description	Note	Qty.
125	barbell holder	Φ25xM12x98	14
126	hexagon bolt	M12x25	14
50	spring washer	Φ12	14
51	washer	Φ12	14

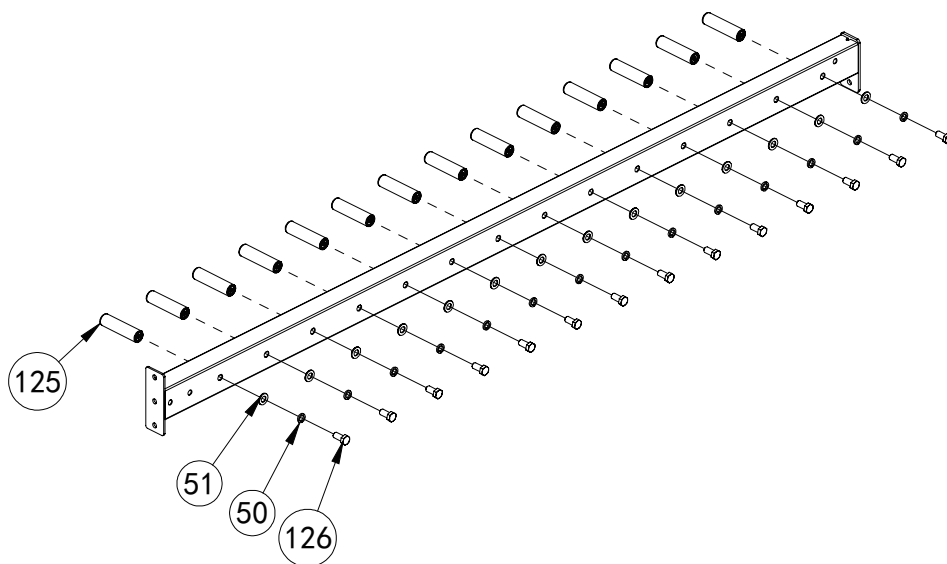

right middle upright frame  
1pcs/set

No.	Description	Note	Qty.
125	barbell holder	Φ25xM12x98	14
126	hexagon bolt	M12x25	14
50	spring washer	Φ12	14
51	washer	Φ12	14

# ASSEMBLY DRAWING

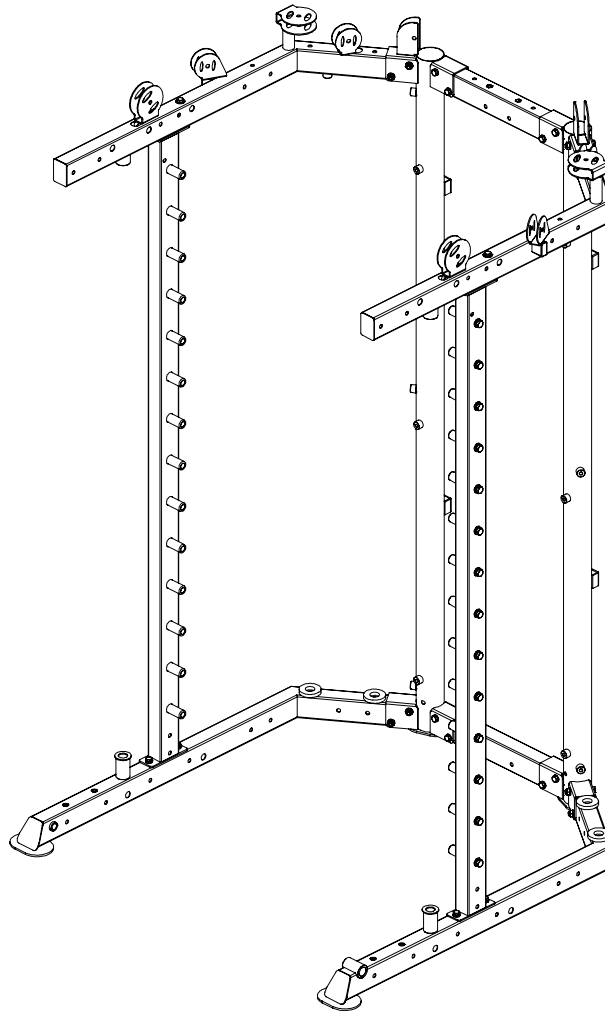

- 1 Attach right upper frame-8, left upper frame-9, right ground frame-10, left ground frame-11 to the mainframe use M10x75 hexagon bolt-5,  $\Phi 10$  washer-7 and M10 lock nut-6
- 2 Attach left middle upright frame-12 and right middle upright frame-13 to the mainframe use M10x25 hexagon bolt-15,  $\Phi 10$  washer-7,  $\Phi 10$  spring washer-14, M10 lock nut-6, big washer-17 and M10x90 hexagon bolt

## ASSEMBLY STEP 3

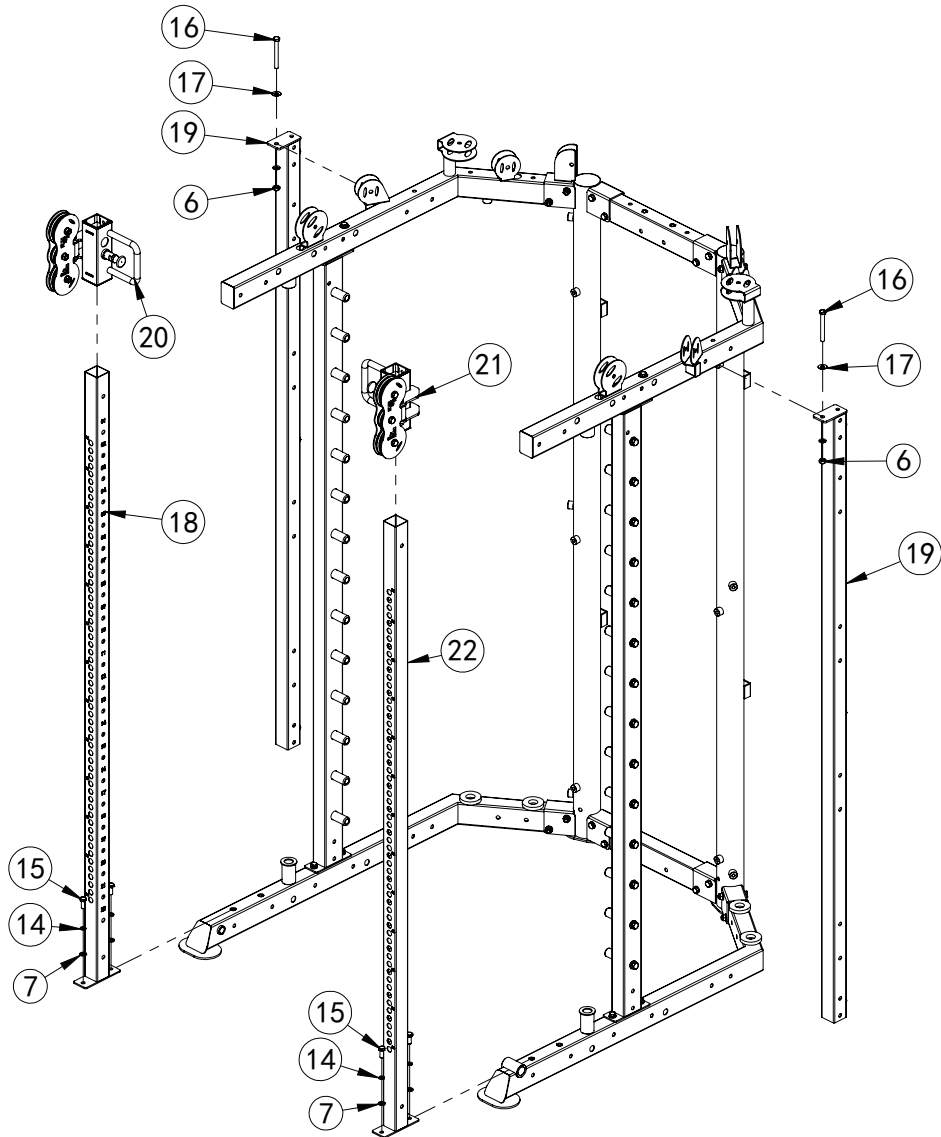

No.	Description	Note	Qty.
18	guide tube		1
19	upright frame		2
20	sliding frame left		1
21	sliding frame right		1
7	washer	Φ10	6
14	spring washer	Φ10	4
15	hexagon bolt	M10x25	4
16	hexagon bolt	M10x90	2
17	big washer	Φ25xΦ10x2	2
6	lock nut	M10	2
22	guide tube		1

# ASSEMBLY DRAWING

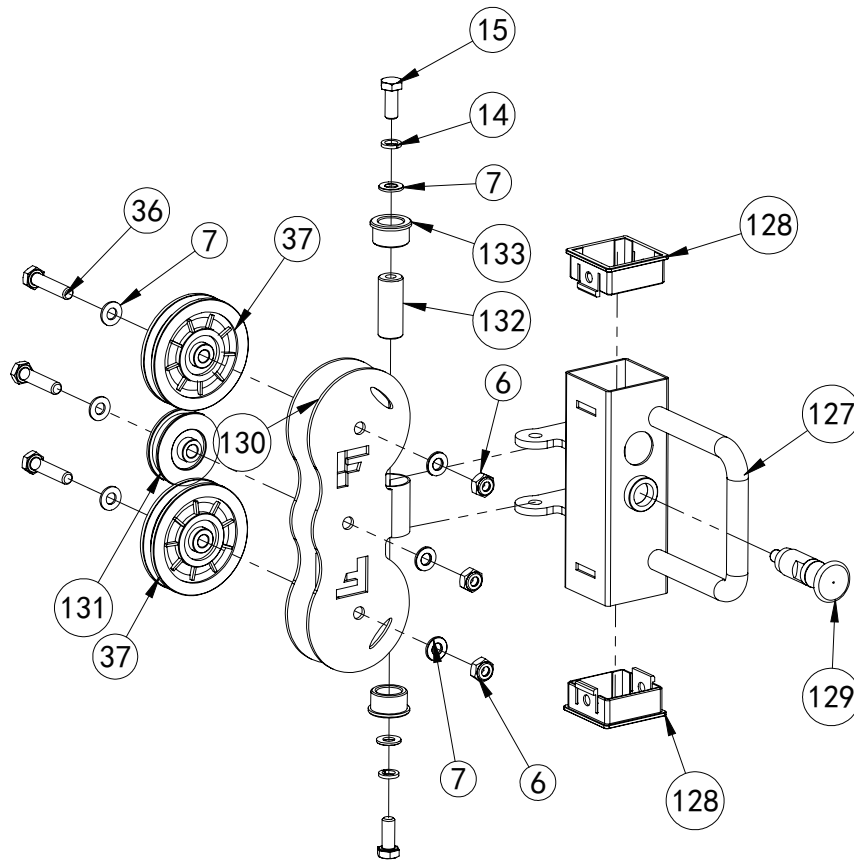

No.	Description	Note	Qty.
127	tube handle left		1
128	plug	50-60	2
129	pin	M20x1.5-Φ10	1
130	pulley bracket		1
37	pulley	Φ92	2
131	pulley	Φ60	1
36	hexagon bolt	M10x45	3
6	lock nut	M10	3
7	washer	Φ10	8
132	internal thread shaft	Φ19.8x49.5	1
133	powder metallurgy sleeve	Φ33xΦ29xΦ20x18	2
14	spring washer	Φ10	2
15	hexagon bolt	M10x25	2

sliding frame left  
1pcs/set



# ASSEMBLY DRAWING

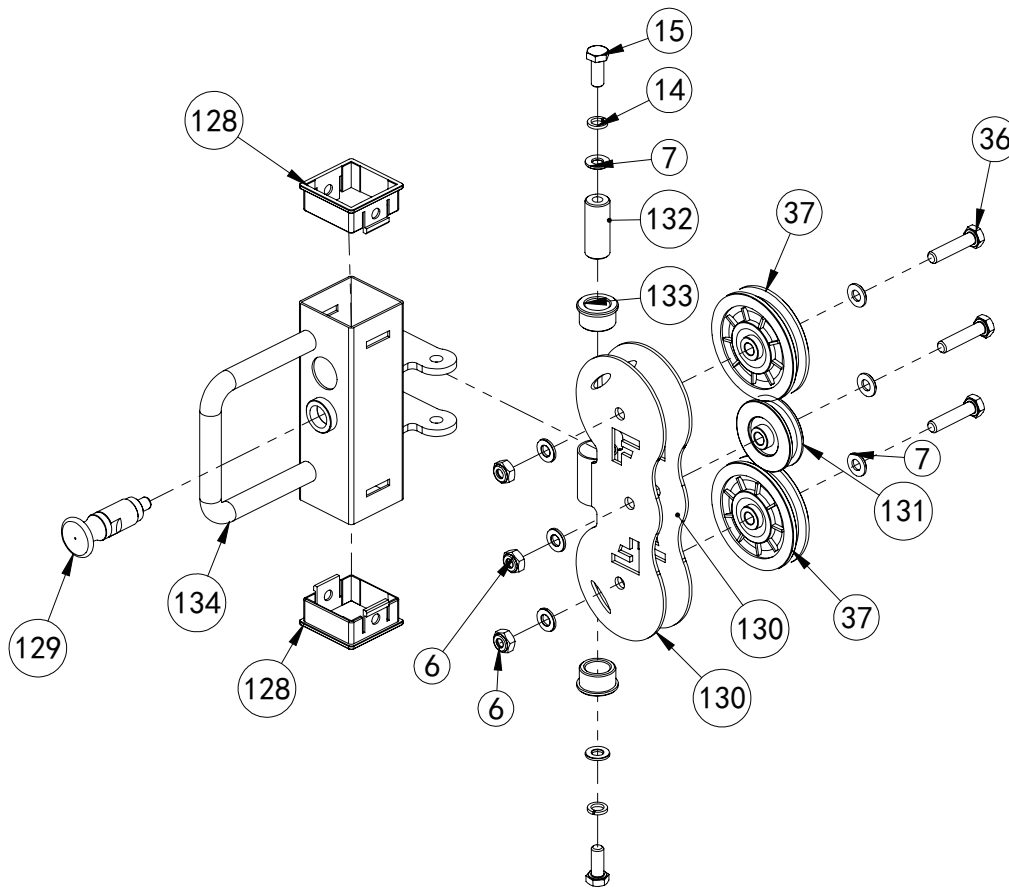

No.	Description	Note	Qty.
134	tube handle right		1
128	plug	50-60	2
129	pin	M20x1.5-Φ10	1
132	internal thread shaft	Φ19.8x49.5	1
133	powder metallurgy sleeve	Φ33xΦ29xΦ20x18	2
15	hexagon bolt	M10x25	2
14	spring washer	Φ10	2
7	washer	Φ10	8
130	pulley bracket		1
37	pulley	Φ92	2
131	pulley	Φ60	1
36	hexagon bolt	M10x45	3
6	lock nut	M10	3

sliding frame right  
1pcs/set

# ASSEMBLY DRAWING

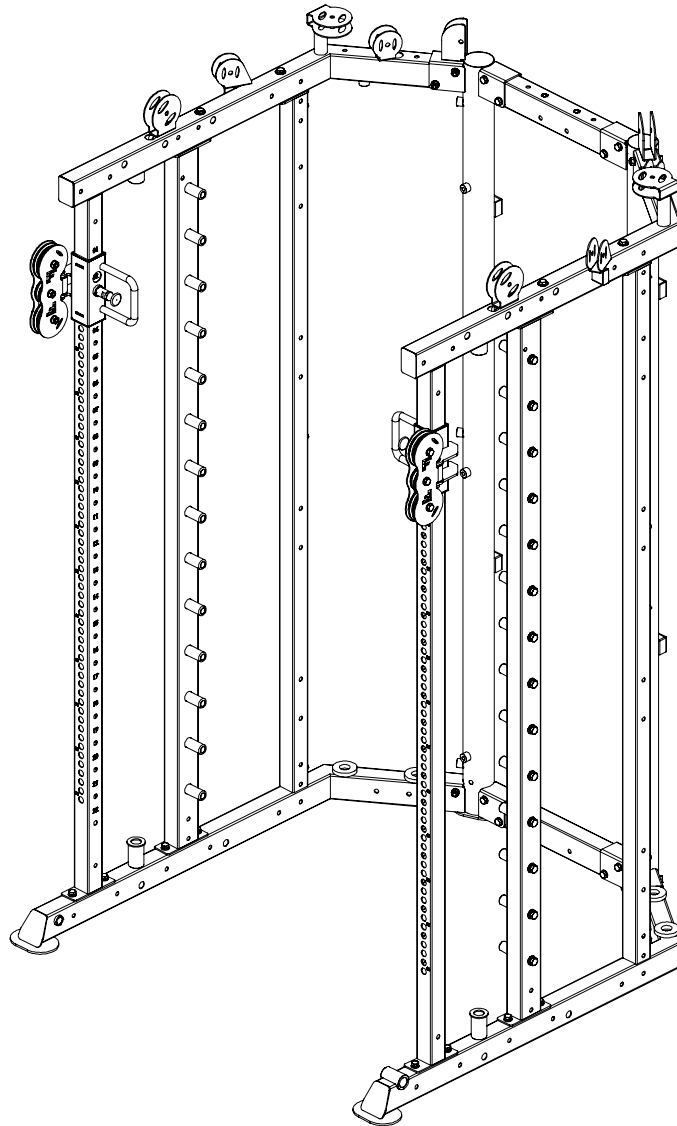

- 1 Attach upright frame-19 to the mainframe use M10x90 hexagon bolt-16,  $\Phi$ 10 washer-7, M10 lock nut-6 and big washer-17
- 2 Put sliding frame left-20 and sliding frame right-21 into guide tube-18 and guide tube right-22  
Attach guide tube-18 and guide tube right-22 to the mainframe use M10x25 hexagon bolt-15,  $\Phi$ 10 washer-7,  $\Phi$ 10 spring washer-14

## ASSEMBLY STEP 4

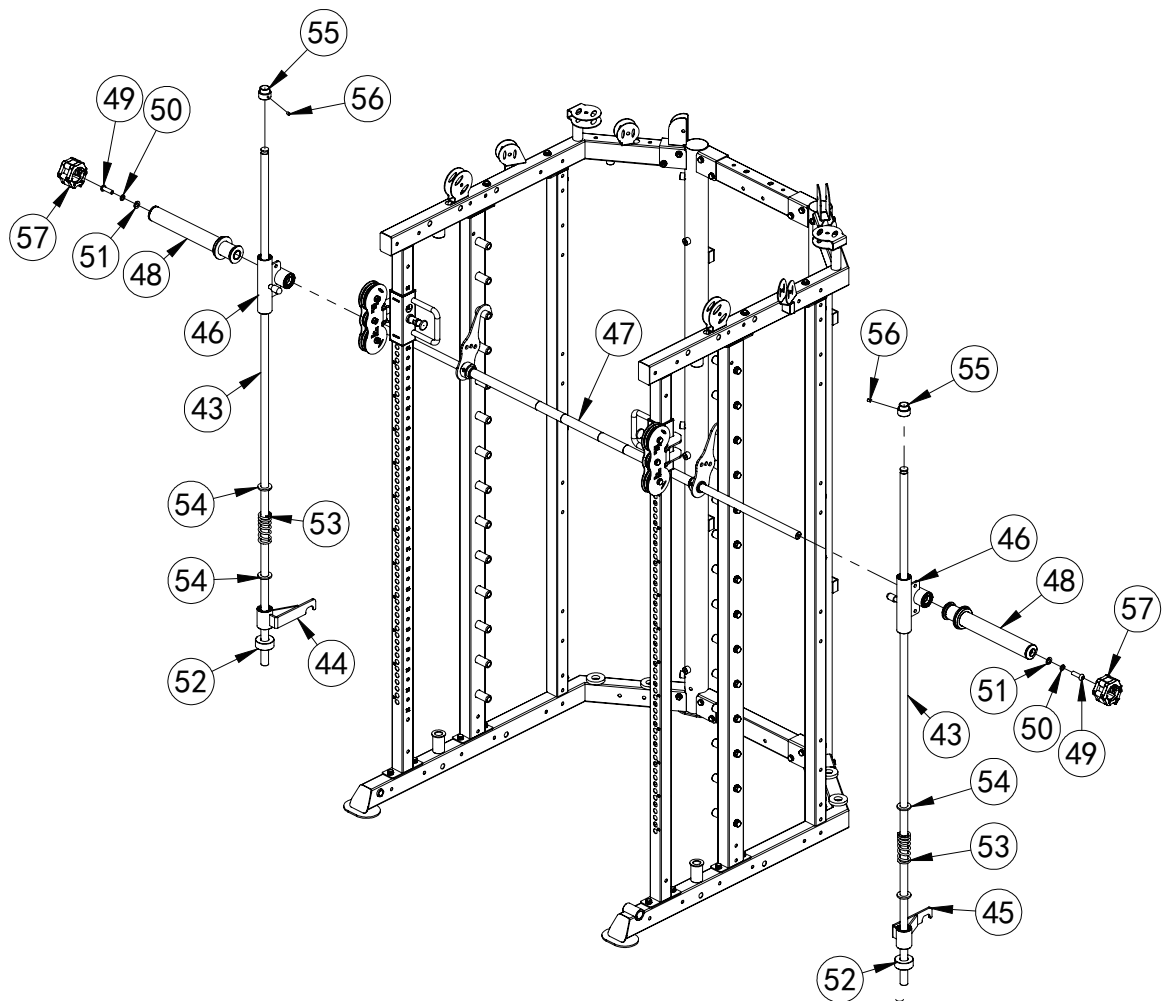

No.	Description	Note	Qty.
43	guide rod	Φ25x1922	2
44	safety hook right		1
45	safety hook left		1
46	sliding sleeve		2
47	barbell rod		1
48	barbell plate holder		2
49	allen bolt	M12x40	2
50	spring washer	Φ12	2
51	washer	Φ12	2
52	rubber block	Φ60xΦ26x25	2
53	spring	Φ6x102	2
54	barbell plate holder ring	Φ45xΦ25.5x5	4
55	guide rod fixing sleeve	Φ40xΦ25.5x35	2
56	screw	M8x10	2
57	barbell rod collar	Φ85xΦ50xH49	2

# ASSEMBLY DRAWING

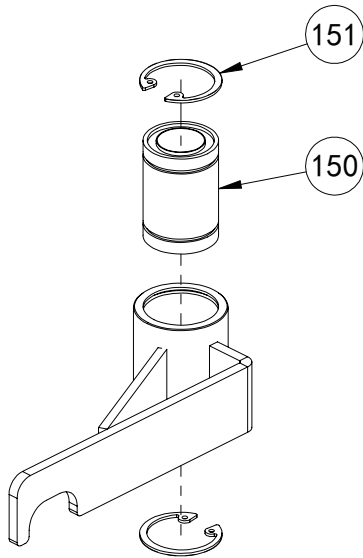

safety hook right&left  
1pcs/set

No.	Description	Note	Qty.
150	bearing	$\Phi 40 \times \Phi 25 \times 58$	1
151	bearing ring		2

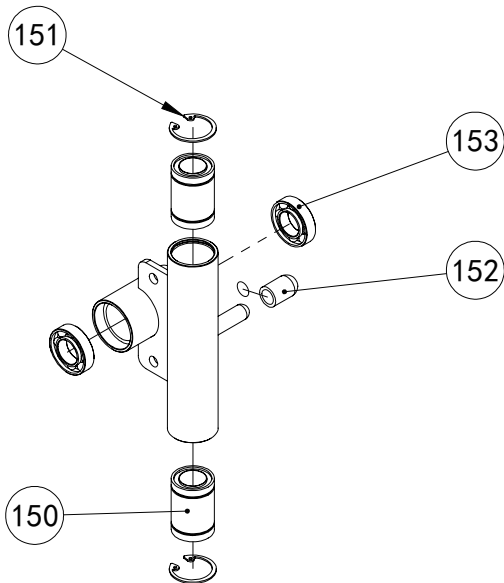

sliding sleeve  
2pcs/set

No.	Description	Note	Qty.
150	bearing	$\Phi 40 \times \Phi 25 \times 58$	2
151	bearing ring		2
152	plastic cover		1
153	bearing	6005	2

# ASSEMBLY DRAWING

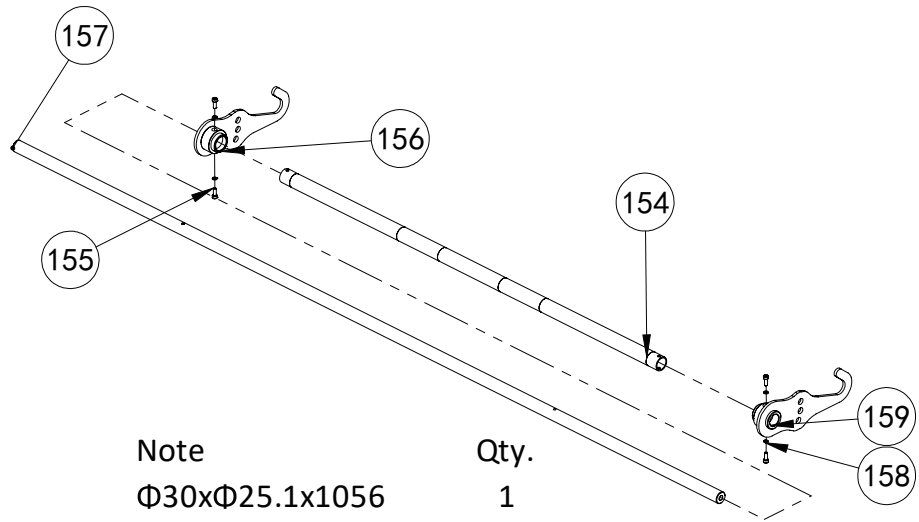

No.	Description	Note	Qty.	
154	barbell rod cover	$\Phi 30 \times \Phi 25.1 \times 1056$	1	
155	screw	M6x16	4	
156	barbell rod hook right		1	
157	barbell inside rod	$\Phi 25 \times 1975$	1	
158	spring washer	$\Phi 6$	4	barbell
159	barbell rod hook left		1	1pcs/set

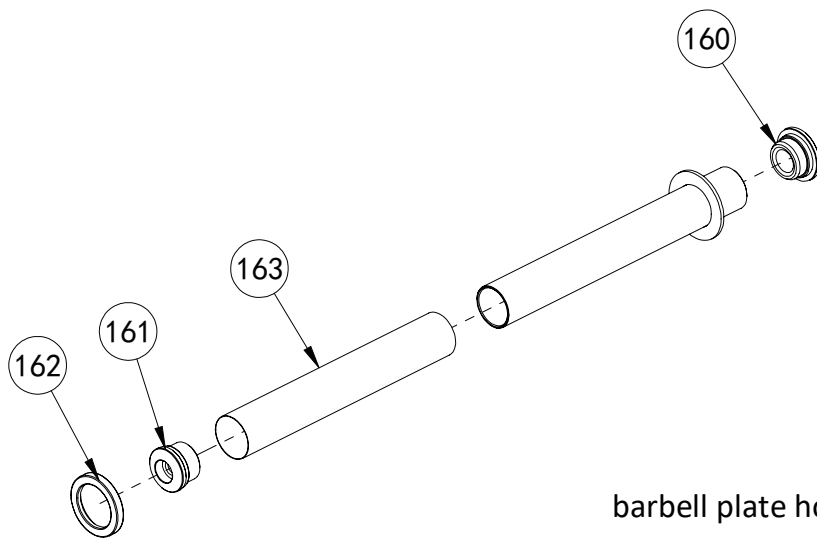

barbell plate holder  
2pcs/set

No.	Description	Note	Qty.
160	ring	$\Phi 60 \times 27$	1
161	end cap	$\Phi 50 \times 37$	1
162	rubber ring	$\Phi 70 \times \Phi 50 \times \Phi 10$	1
163	tube	$\Phi 49.5 \times 0.6$	1

# ASSEMBLY DRAWING

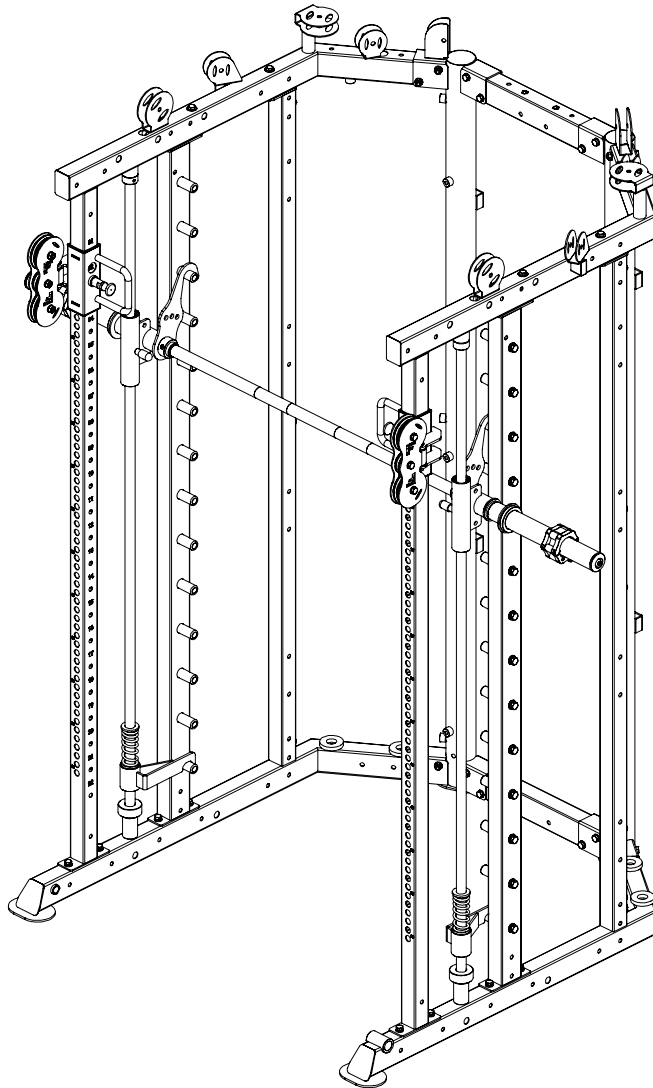

- 1 Put barbell rod-47 on the mainframe
- 2 Guide rod-43 in turn insert rubber block-52, safety hook-44&45, barbell plate holder ring-54, spring-53, sliding sleeve-46  
Attach sliding sleeve-46 to the mainframe
- 3 Attach guide rod-43 to the mainframe use guide rod fixing sleeve-55, screw-56
- 4 Attach barbell plate holder-48 to barbell rod-47 use M12x40 allen bolt-49,  $\Phi$ 12 washer-51,  $\Phi$ 12 spring washer-50
- 5 Put barbell rod collar-57 onto barbell plate holder-48

# ASSEMBLY STEP 5

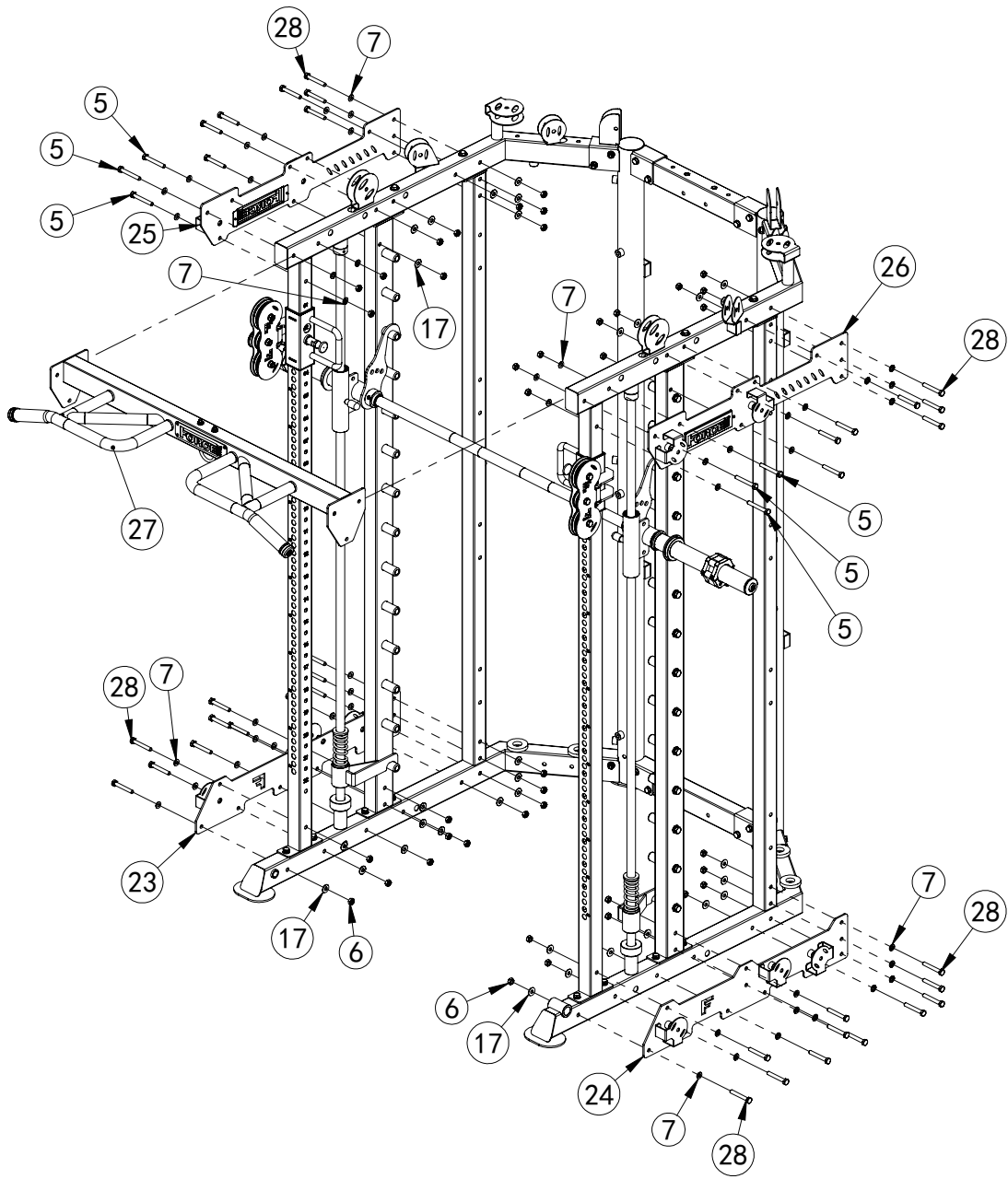

No.	Description	Note	Qty.
23	down pulley cover left		1
24	down pulley cover right		1
25	up pulley cover left		1
26	up pulley cover right		1
27	chin up frame		1
28	hexagon bolt	M10x70	36
6	lock nut	M10	42
17	big washer	Φ25xΦ10x2	36
7	washer	Φ10	48
5	hexagon bolt	M10x75	6

# ASSEMBLY DRAWING

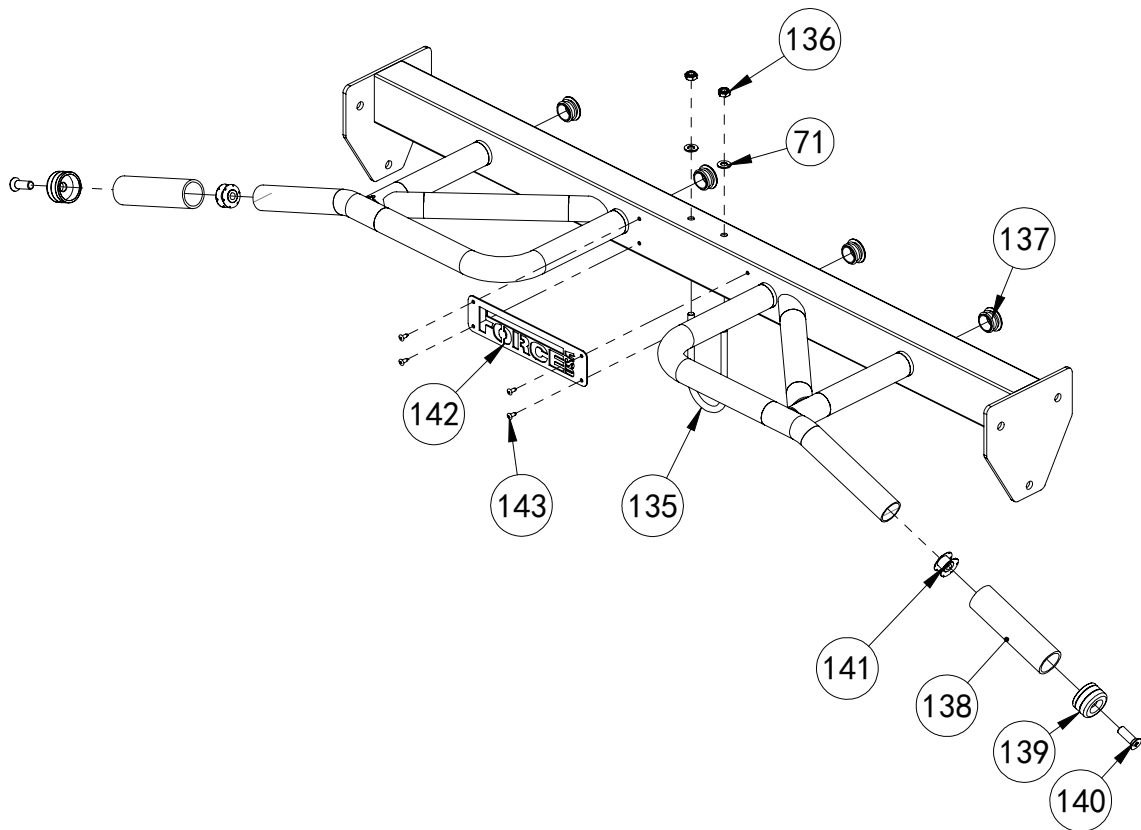

chin up frame  
1pcs/set

No.	Description	Note	Qty.
135	U hook		1
71	washer	Φ8	2
136	lock nut	M8	2
137	round plug	Φ32x1.5	4
138	handle cover	Φ38xΦ32x130	2
139	ring	Φ38x32x25	2
140	screw	M10x25	2
141	insert nut	Φ29.3-M10	2
142	logo plate		1
143	hollow rivet	4x8	4



# ASSEMBLY DRAWING

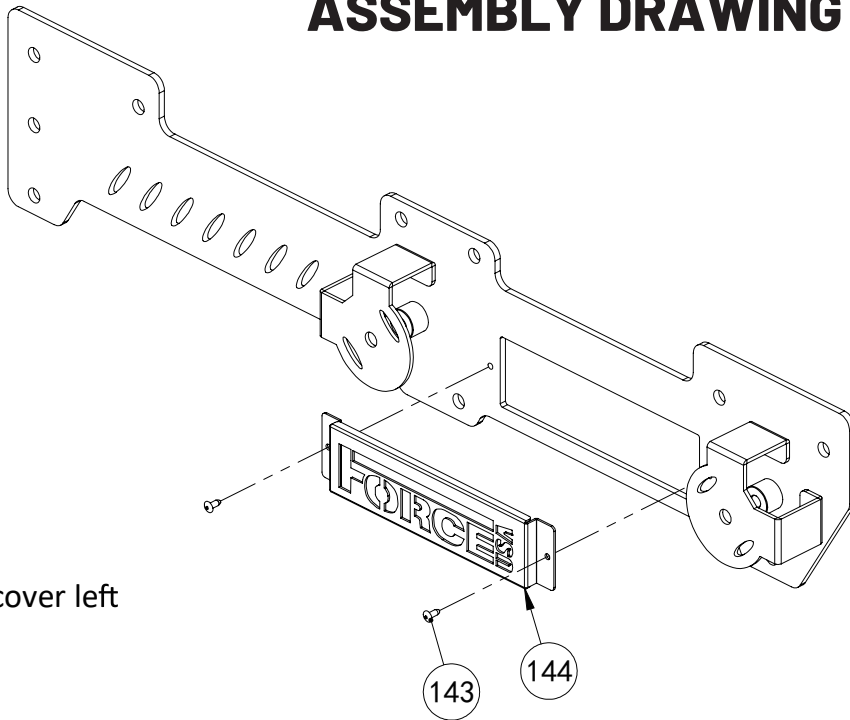

up pulley cover left  
1pcs/set

No.	Description	Note	Qty.
143	hollow rivet	4x10	2
144	logo plate		1

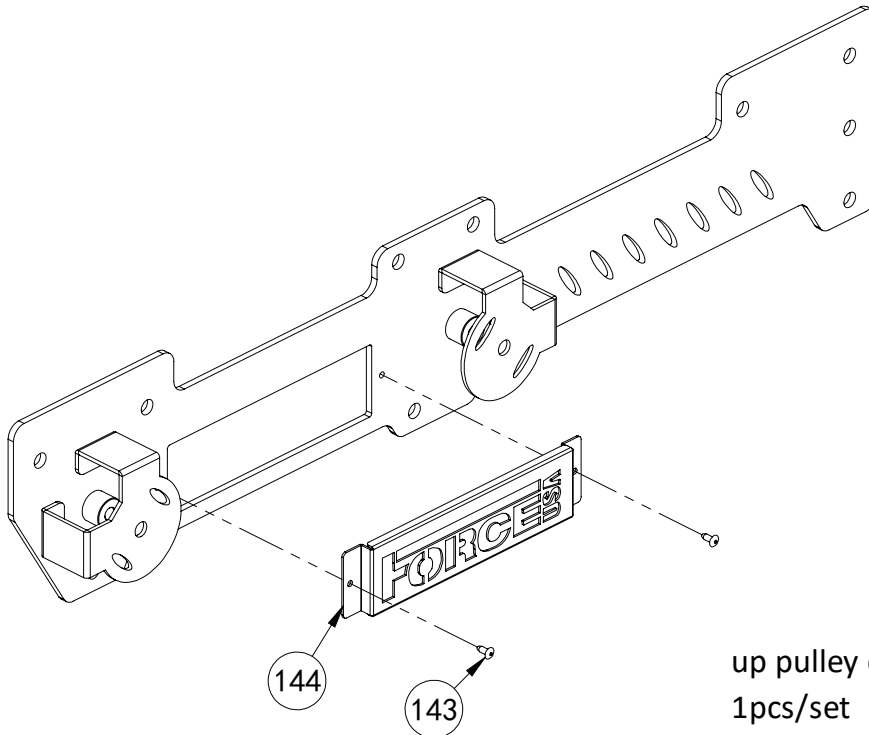

up pulley cover right  
1pcs/set

No.	Description	Note	Qty.
143	hollow rivet	4x10	2
144	logo plate		1

# ASSEMBLY DRAWING

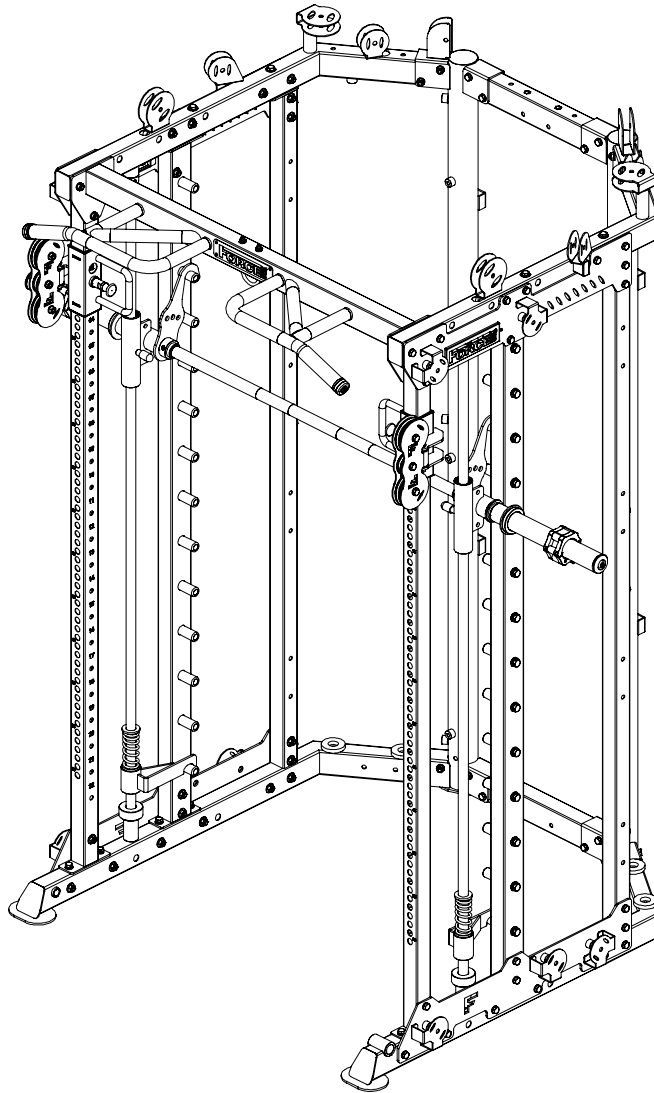

1 Attach up pulley cover left-25, up pulley cover right-26, down pulley cover left-23, down pulley cover right-24 to the mainframe use M10x70 hexagon bolt-28,  $\Phi$ 10 washer-7, M10 lock nut-6 and big washer-17

2 Attach chin up frame-27 to the mainframe use M10x75 hexagon bolt-5,  $\Phi$ 10 washer-7 and M10 lock nut-6

## ASSEMBLY STEP 6

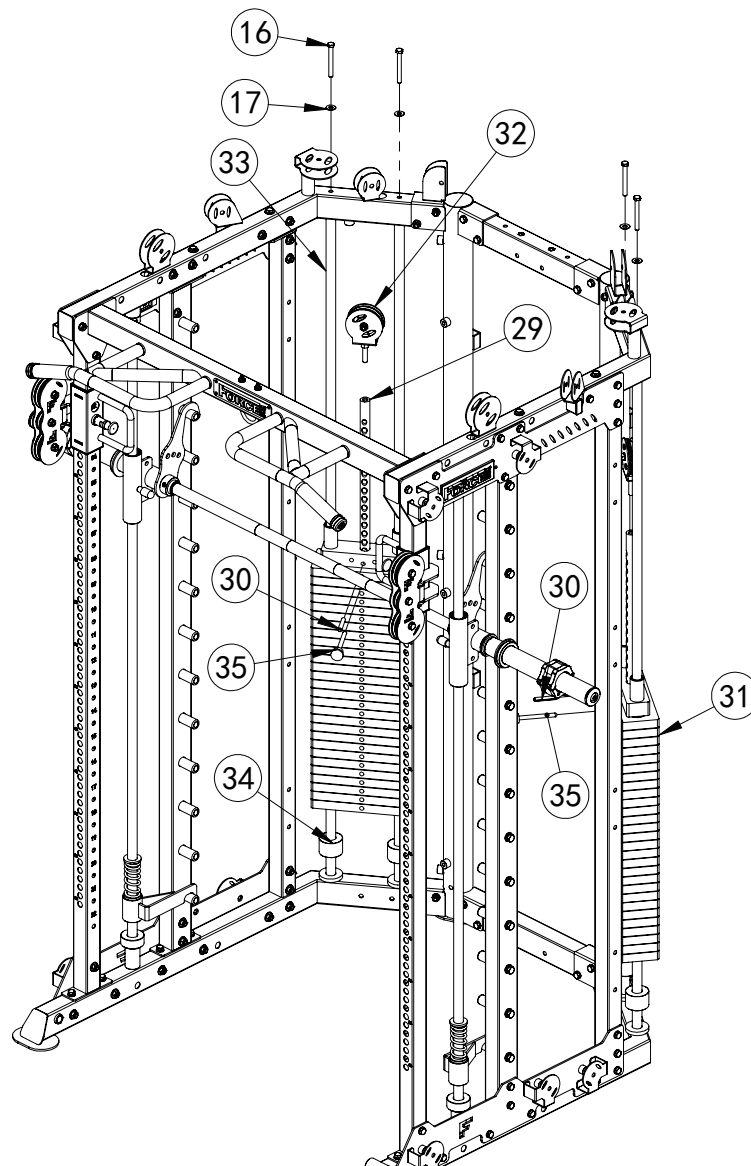

No.	Description	Note	Qty.
29	selector rod	Φ25x798	2
30	pin	10x60	2
31	weight group	28+1(130KG)	2
32	pulley bracket		2
33	guide rod		4
34	rubber block	Φ60xΦ27x42	4
35	pin	Φ10x100	2
16	hexagon bolt	M10x90	4
17	big washer	Φ25xΦ10x2	4

# ASSEMBLY DRAWING

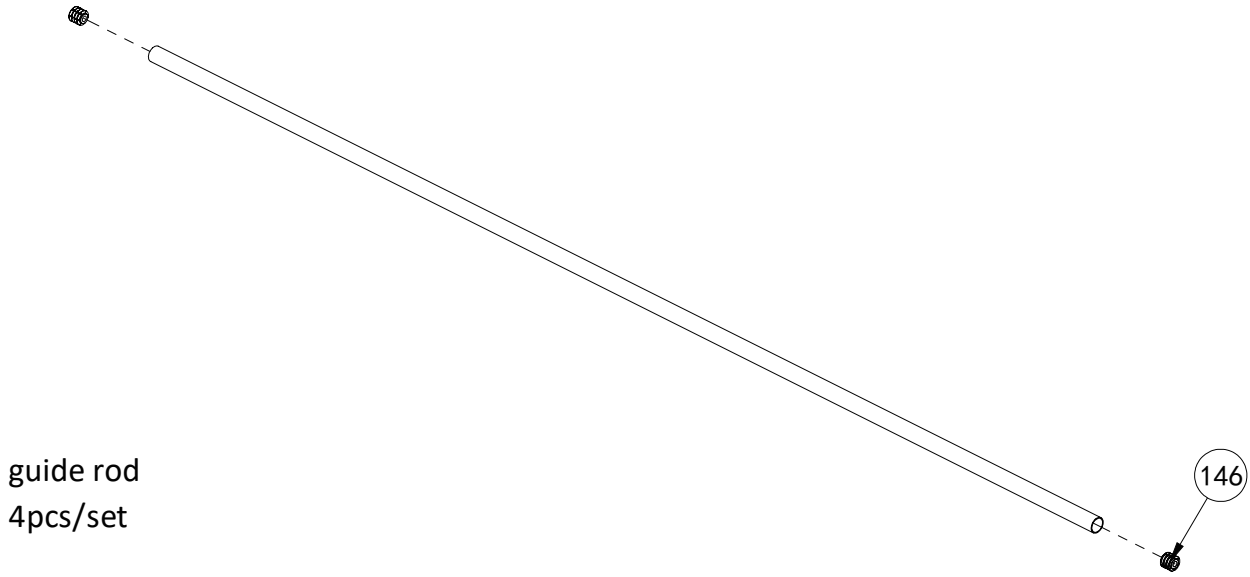

No.	Description	Note	Qty.
146	insert nut	Φ23-M10-4F	2

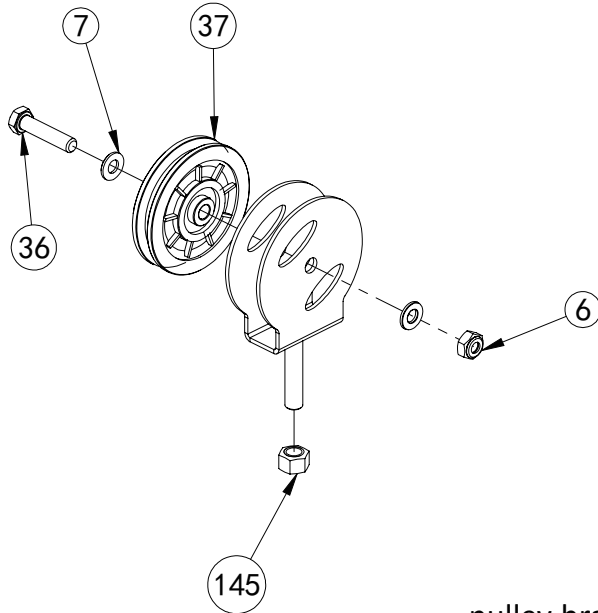

No.	Description	Note	Qty.
36	hexagon bolt	M10x45	1
37	pulley	Φ92	1
6	lock nut	M10	1
7	washer	Φ10	2
145	lock nut	M12	1

pulley bracket  
2pcs/set

# ASSEMBLY DRAWING

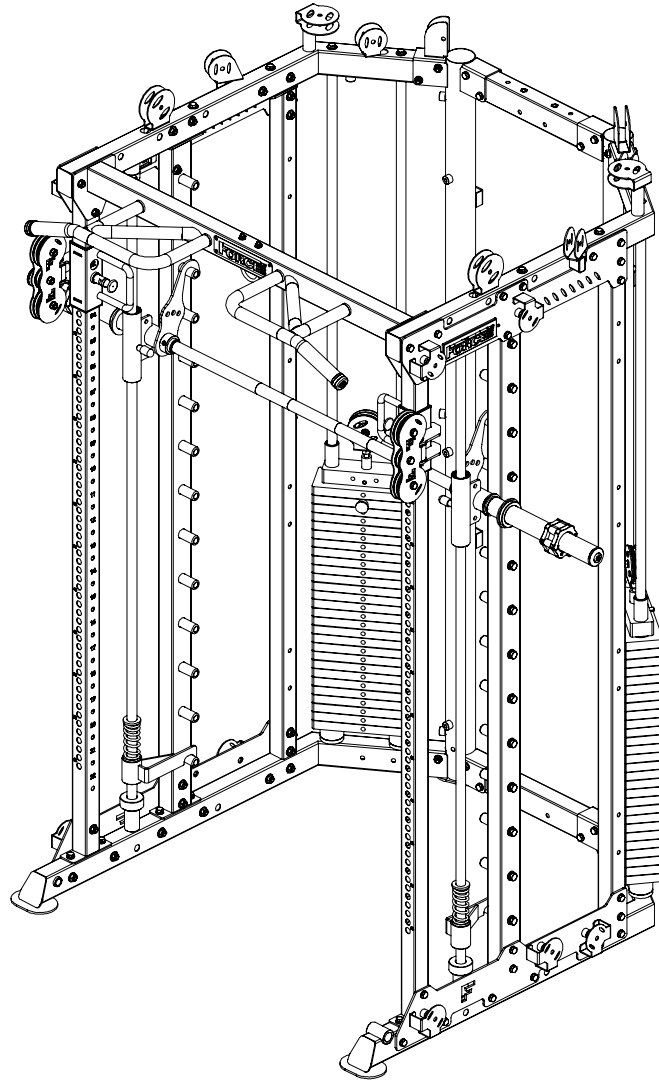

- 1 As the shown guide rod-33 in turn cross rubber block-34 and weight group-31, then attach to mainframe use M10x90 hexagon bolt-16 and big washer-17
- 2 Insert pin-30 into selector rod-29 and insert pin-35 into weight group
- 3 Attach pulley bracket-32 to selector rod-29

# ASSEMBLY STEP 7

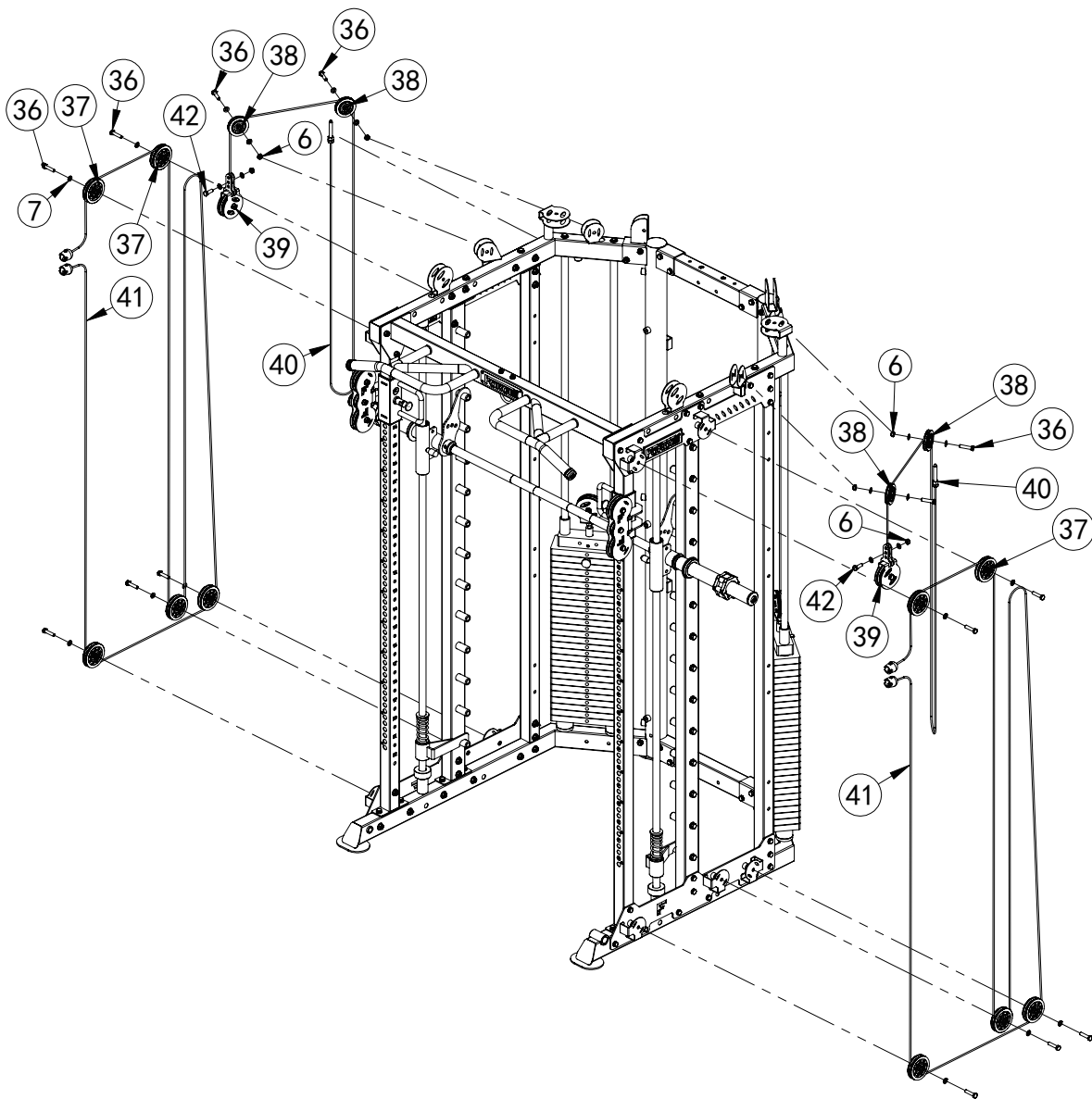

No.	Description	Note	Qty.
36	hexagon bolt	M10x45	14
7	washer	Φ10	22
37	pulley	Φ92	10
6	lock nut	M10	6
38	pulley	Φ75	4
39	pulley frame		2
40	cable		2
41	cable		2
42	hexagon bolt	M10x30	2

# ASSEMBLY DRAWING

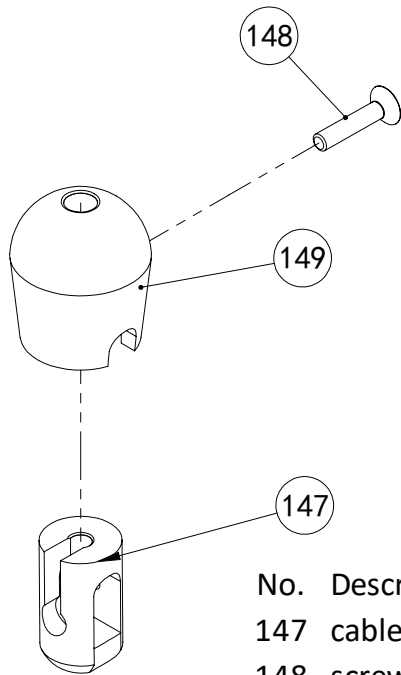

cable ball  
4pcs/set

No.	Description	Note	Qty.
147	cable end		1
148	screw	M5x25	1
149	cable ball		1

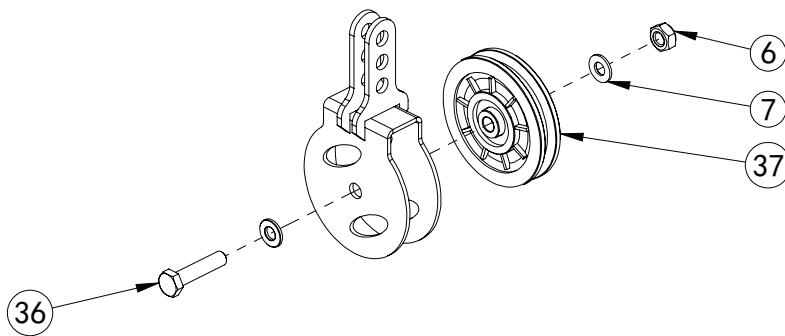

pulley frame  
2pcs/set

No.	Description	Note	Qty.
36	hexagon bolt	M10x45	1
6	lock nut	M10	1
7	washer	Φ10	2
37	pulley	Φ92	1

# ASSEMBLY DRAWING

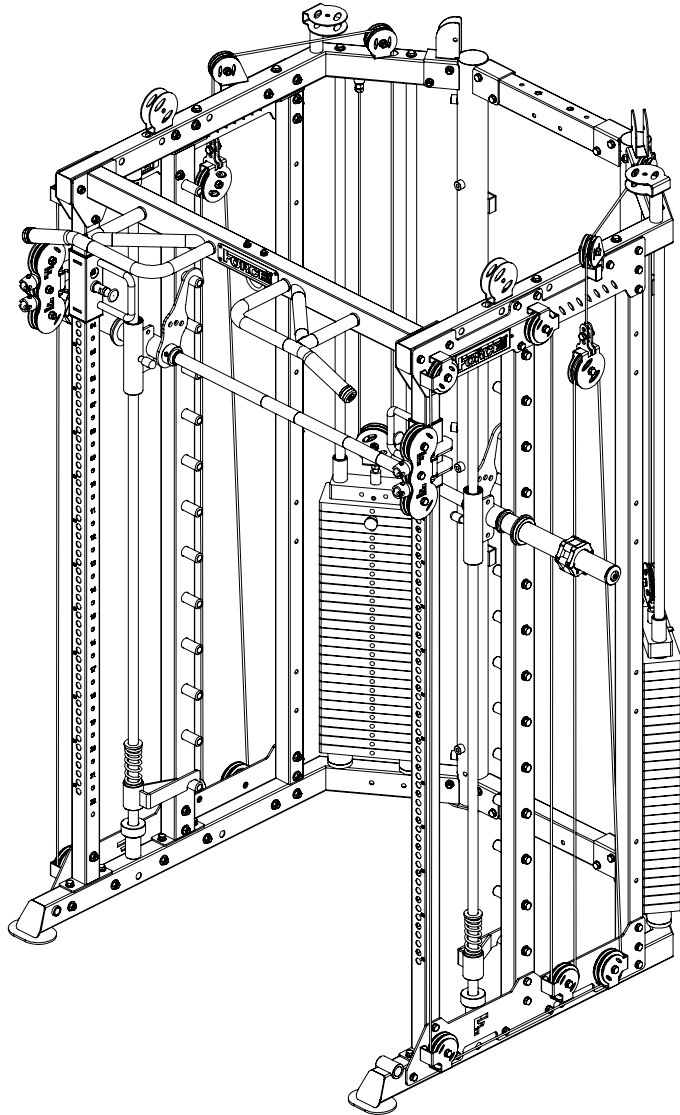

- 1 Attach  $\Phi 92$  pulley-37,  $\Phi 75$  pulley-38 on pulley frame use M10x45 hexagon bolt-36,  $\Phi 10$  washer-7 and M10 lock nut-6  
As the shown attach the cable-41 to the mainframe
- 2 Attach pulley frame-39 on cable-41 use M10x30 hexagon bolt-42,  $\Phi 10$  washer-7 and M10 lock nut-6
- 3 Disassemble one end cable-41 and thread the wire rope according the picture



# ASSEMBLY STEP 8

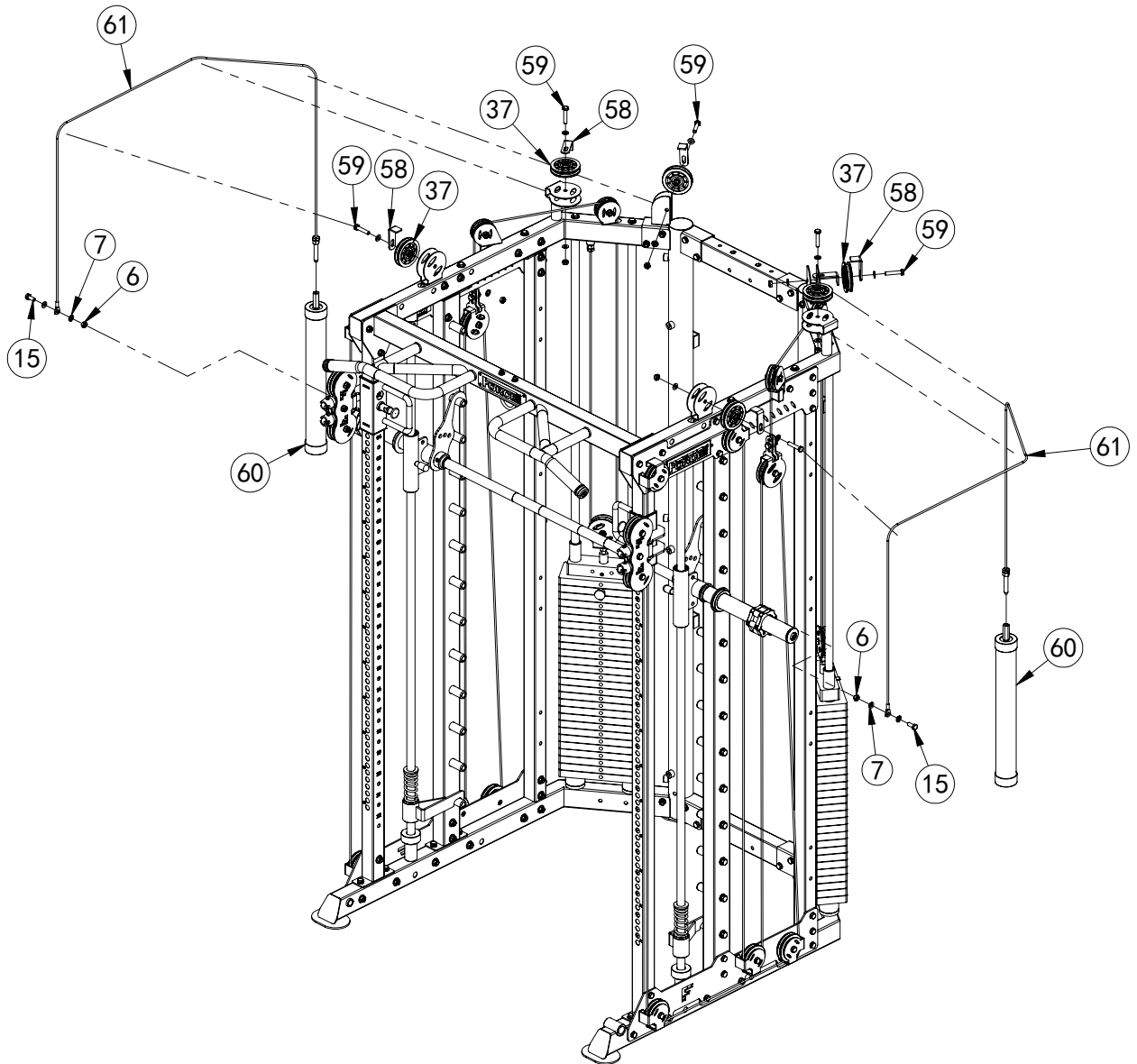

No.	Description	Note	Qty.
7	washer	Φ10	16
6	lock nut	M10	8
37	pulley	Φ92	6
58	plastic strip		6
59	hexagon bolt	M10x50	6
60	weight		2
61	cable		2
15	hexagon bolt	M10x25	2

# ASSEMBLY DRAWING

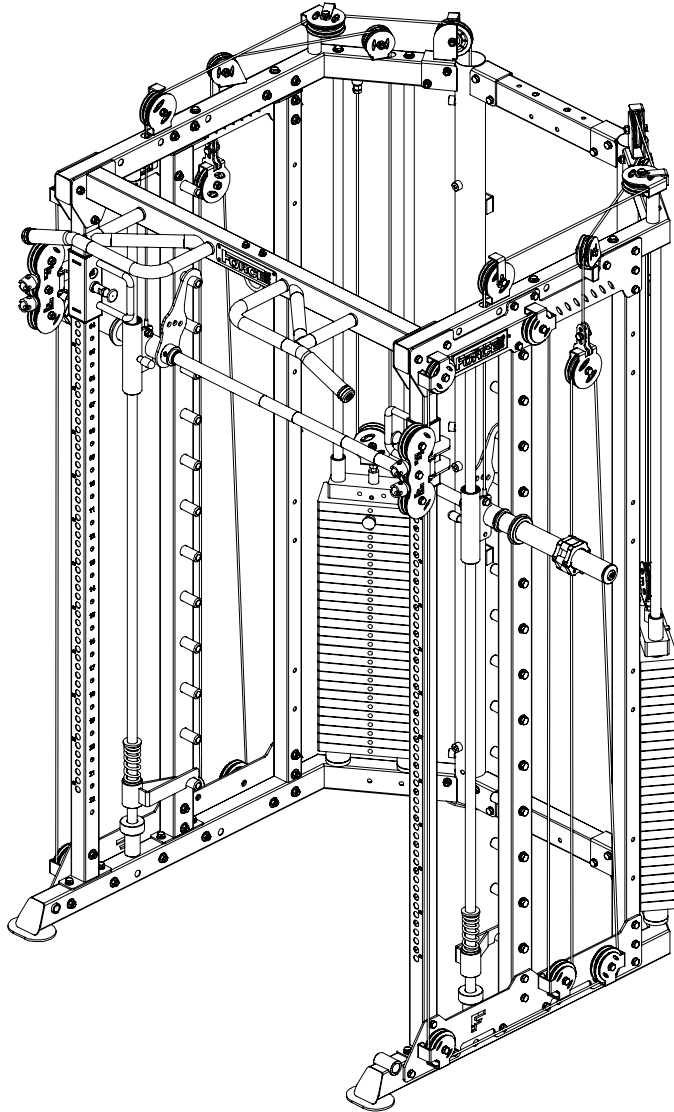

1 Attach  $\Phi 92$  pulley-37 on the mainframe use M10x50 hexagon bolt-59,  $\Phi 10$  washer-7 and M10 lock nut-6

2 Link cable-61 with weight-60

Attach cable-61 on sliding sleeve-46 use M10x25 hexagon bolt-15,  $\Phi 10$  washer-7 and M10 lock nut-6 according the picture cable route

# ASSEMBLY STEP 9

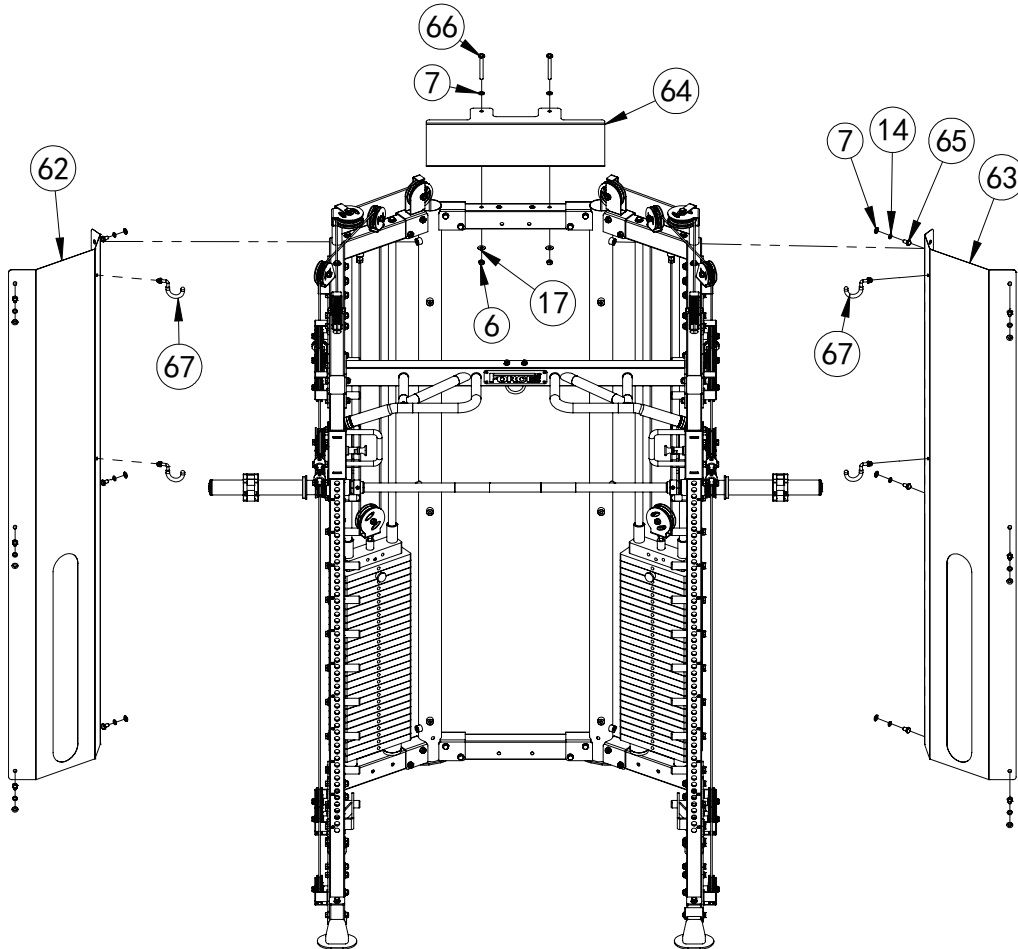

No.	Description	Note	Qty.
62	weight plate cover left		1
63	weight plate cover right		1
64	logo board		1
7	washer	Φ10	14
14	spring washer	Φ10	12
65	hexagon bolt	M10x16	12
17	big washer	Φ25xΦ10x2	2
6	lock nut	M10	2
66	hexagon bolt	M10x85	2
67	hook		4

# ASSEMBLY DRAWING

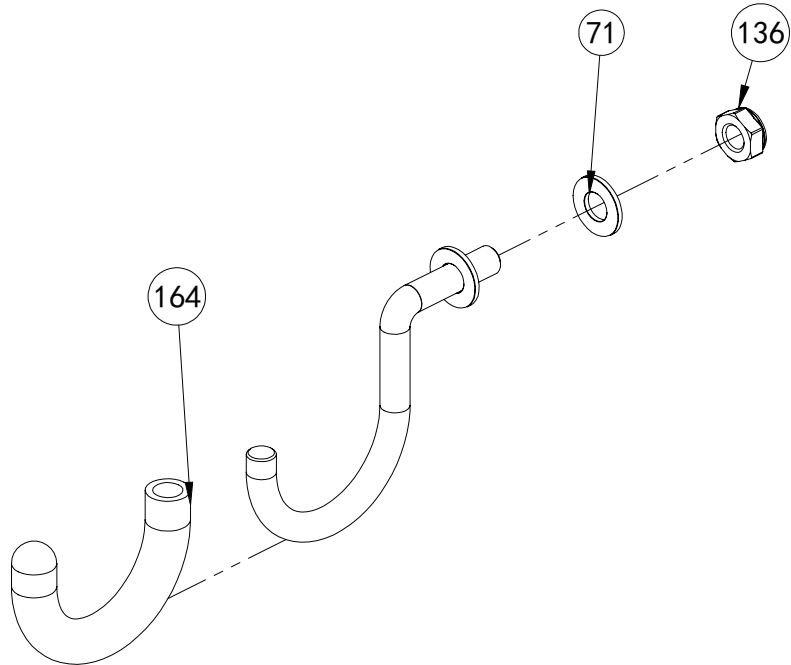

No.	Description	Note	Qty.
164	hook cover	Φ8x100	1
71	washer	Φ8	1
136	lock nut	M8	1

hook  
4pcs/set

# ASSEMBLY DRAWING

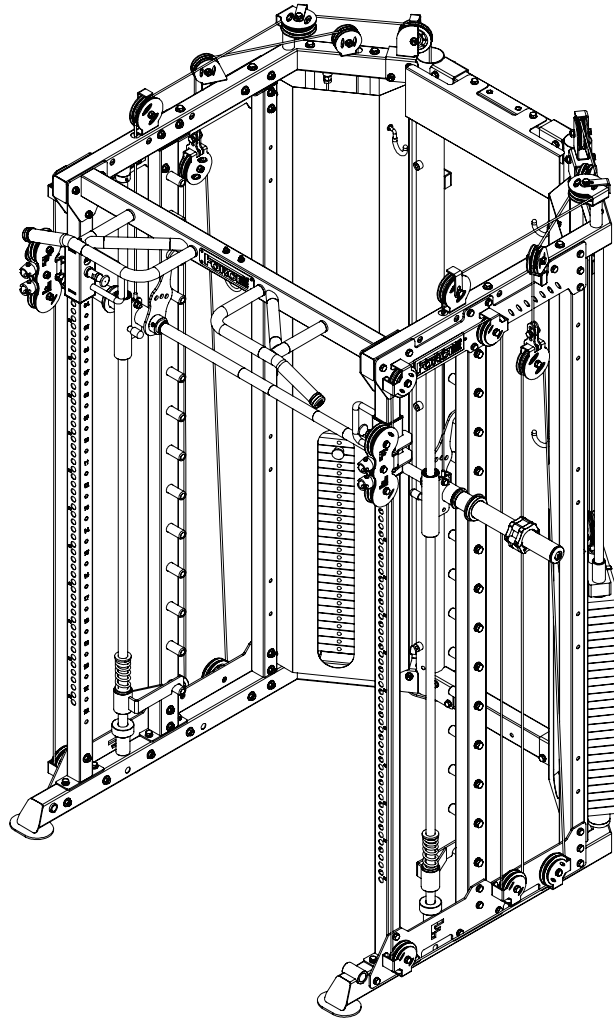

- 1 Attach weight plate cover left-62, weight plate cover right-63 to the mainframe use M10x16 hexagon bolt-65,  $\Phi$ 10 washer-7,  $\Phi$ 10 spring washer-14
- 2 Attach hook-67 on the weight plate cover according the picture
- 3 Attach logo board-64 to the mainframe use M10x85 hexagon bolt-66,  $\Phi$ 10 washer-7, M10 lock nut-6, big washer-17

# ASSEMBLY STEP 10

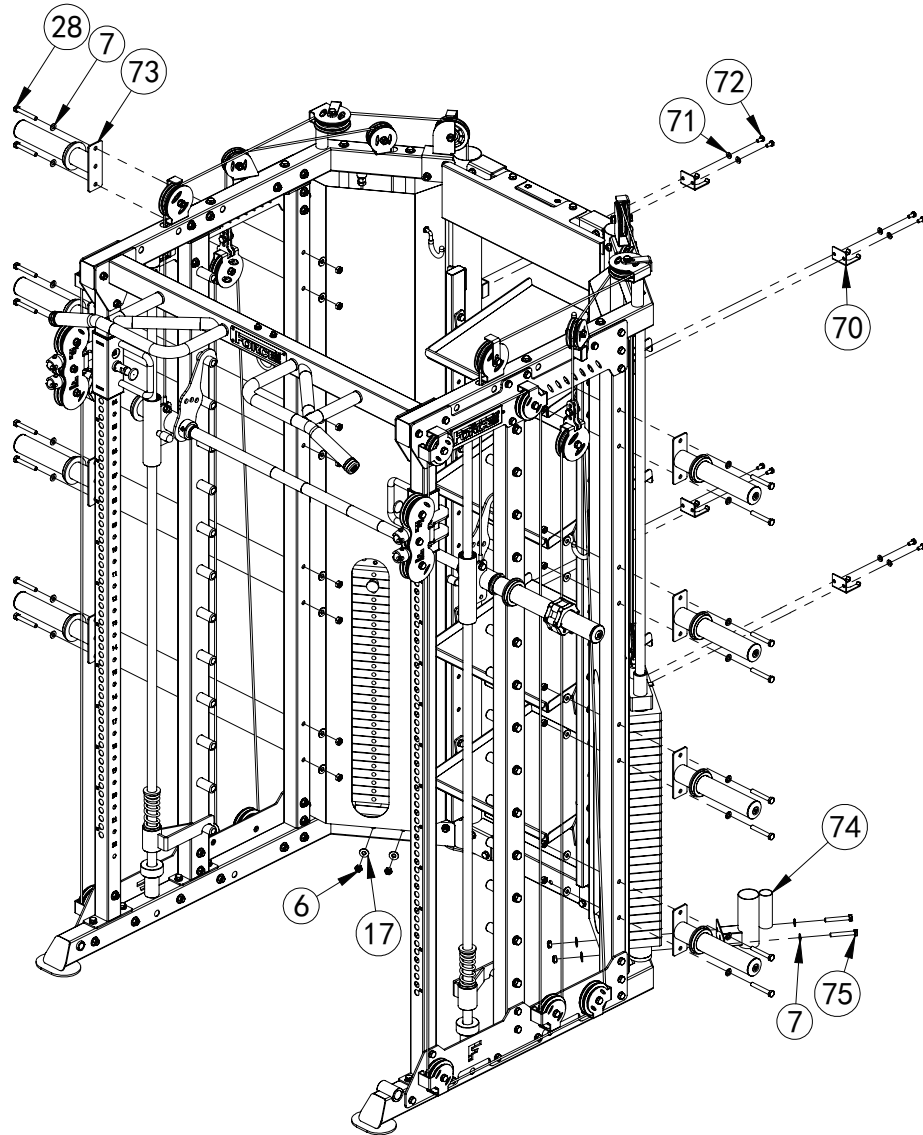

No.	Description	Note	Qty.
70	hook		4
71	washer	Φ8	8
72	hexagon bolt	M8x16	8
73	barbell plate holder		8
28	hexagon bolt	M10x70	16
6	lock nut	M10	20
7	washer	Φ10	20
17	big washer	Φ25xΦ10x2	20
74	barbell rod cup		2
75	hexagon bolt	M10x65	4

# ASSEMBLY DRAWING

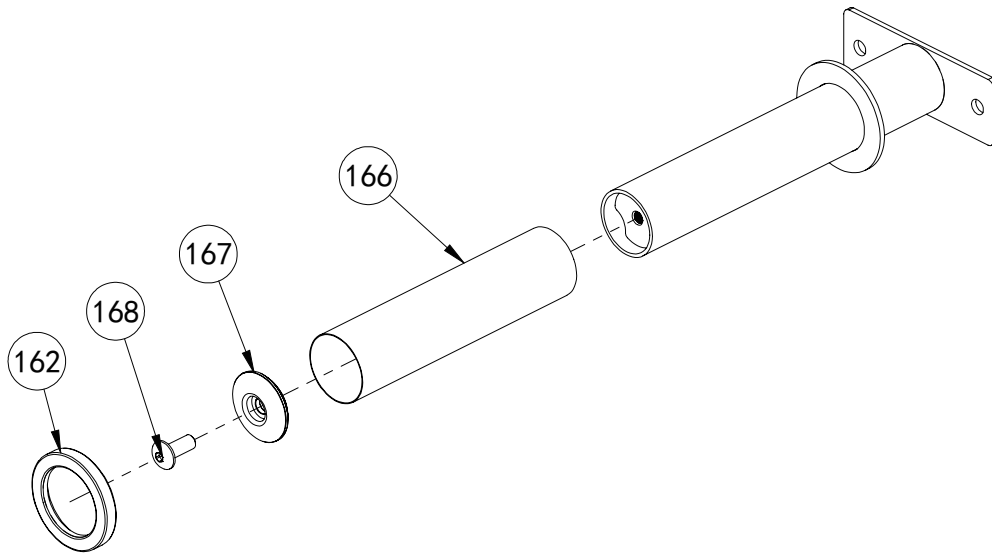

barbell plate holder  
8pcs/set

No.	Description	Note	Qty.
166	tube	$\Phi 49.6 \times 0.6 \times 200$	1
167	end cap	$\Phi 11 \times \Phi 18 \times \Phi 42 \times \Phi 50$	1
168	allen bolt	M10x25	1
162	rubber ring	$\Phi 70 \times \Phi 50 \times \Phi 10$	1

# ASSEMBLY DRAWING

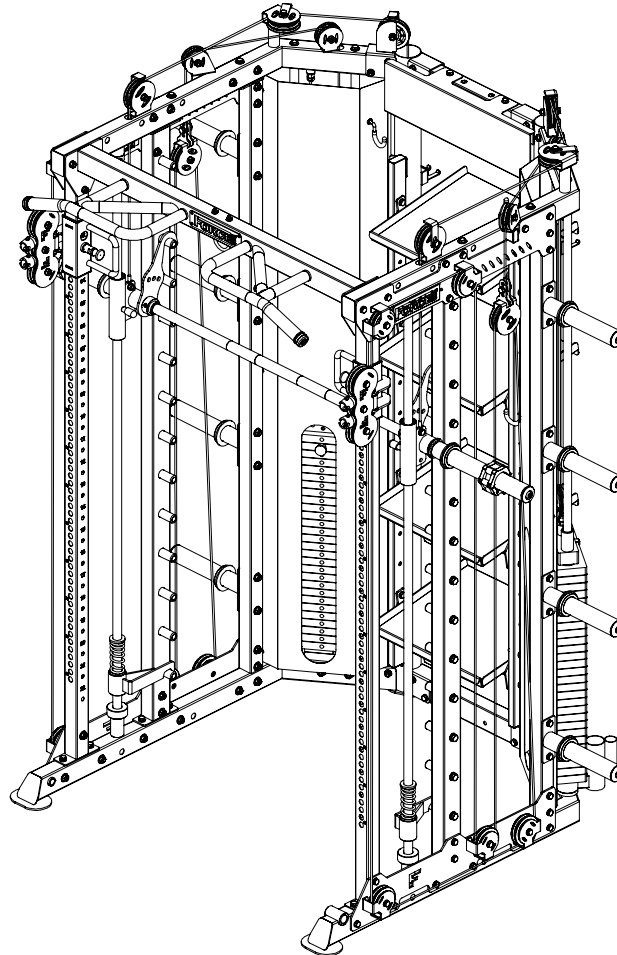

- 1 Attach hook-70 on the mainframe use M8x16 hexagon bolt-72 and  $\Phi 8$  washer-71
- 2 Attach barbell rod cup-74 to the mainframe use M10x70 hexagon bolt-28,  $\Phi 10$  washer-7, M10 lock nut-6, big washer-17
- 3 Attach barbell plate holder-73 to the mainframe use M10x65 hexagon bolt-75,  $\Phi 10$  washer-7, M10 lock nut-6, big washer-17



# ASSEMBLY STEP 11

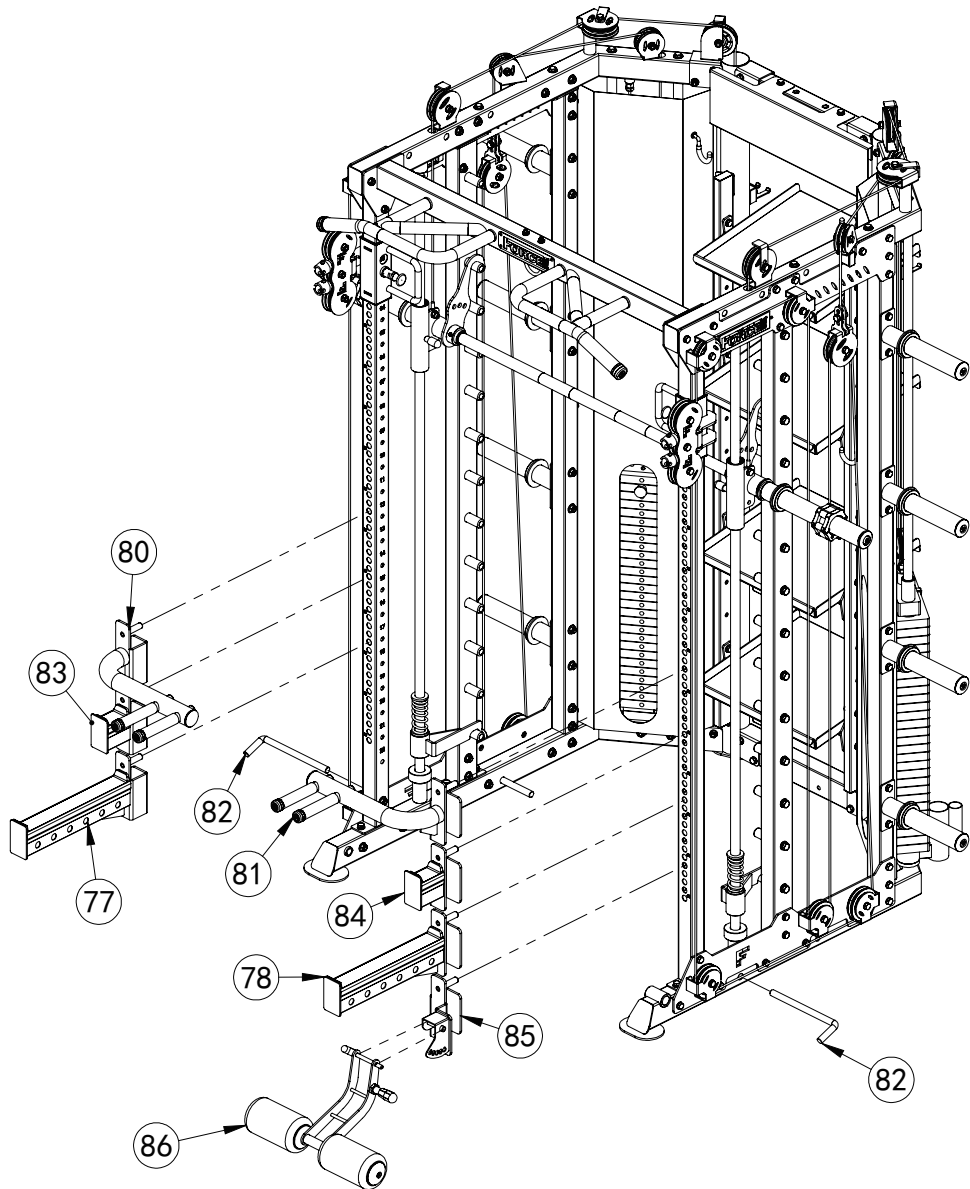

No.	Description	Qty.
77	long barbell rod holder right	1
78	long barbell rod holder left	1
80	dip bar right	1
81	dip bar left	1
82	L shape pin	3
83	short barbell rod holder right	1
84	short barbell rod holder left	1
85	selector part	1
86	leg curl frame	1

# ASSEMBLY DRAWING

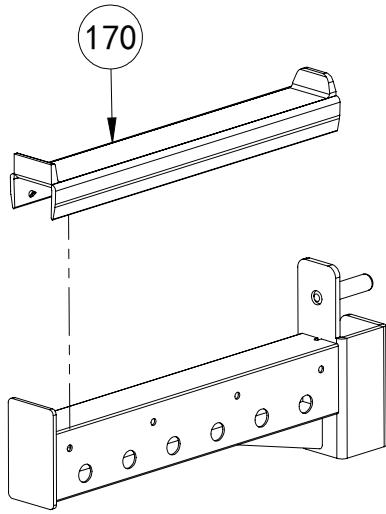

long barbell rod holder right&left  
1pcs/set

No.	Description	Note	Qty.
170	rubber cover long	387	1

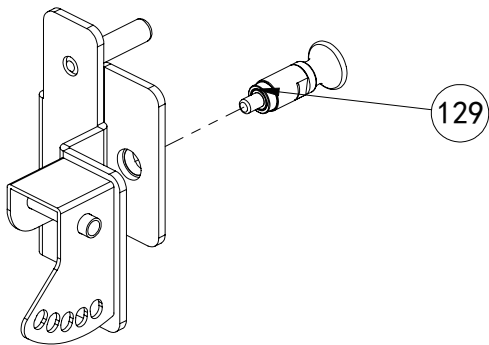

No.	Description	Note	Qty.
129	pin	M20x1.5-Φ10	1

selector part  
1pcs/set

# ASSEMBLY DRAWING

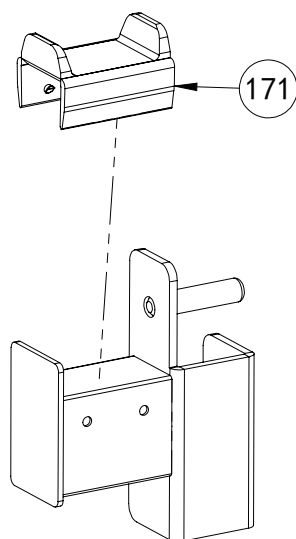

short barbell rod holder right&left  
1pcs/set

No.	Description	Note	Qty.
171	rubber cover short	85	1

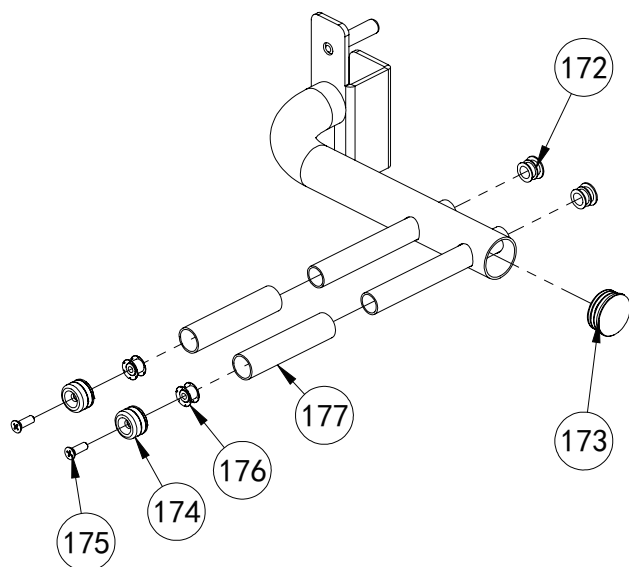

dip bar right&left  
1pcs/set

No.	Description	Note	Qty.
172	plug	Φ25x2	2
173	plug	Φ48x2.5	1
174	ring	Φ31.5xΦ25.5	2
175	screw	M8x20	2
176	insert nut	Φ23-M8	2
177	handle cover	Φ25x125	2

# ASSEMBLY DRAWING

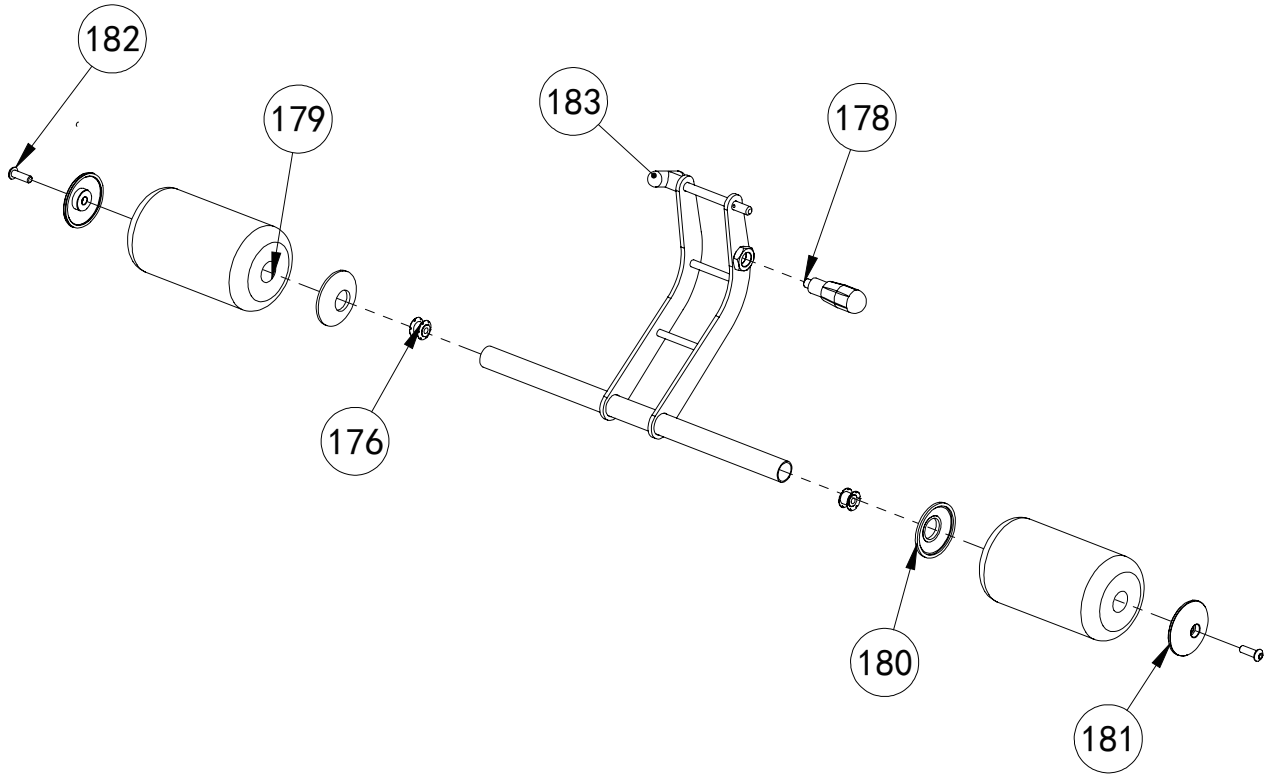

leg curl frame  
1pcs/set

No.	Description	Note	Qty.
178	lock pin	M18x12xΦ10	1
179	foam	Φ25xΦ100x175	2
180	foam inner cover	Φ65xΦ25x12	2
181	foam outer cover	Φ65xΦ9x13	2
182	allen bolt	M8x25	2
176	insert nut	Φ23-M8	2
183	T pin	Φ10x100	1

# ASSEMBLY DRAWING

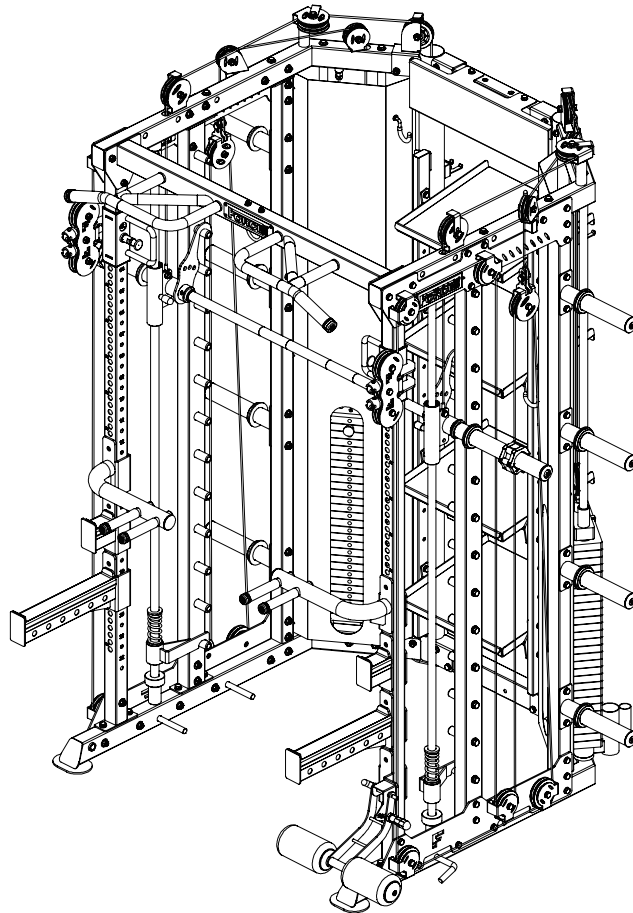

- 1 Put long barbell rod holder-77&78, ,dip bar-80&81, L shape pin-82, short barbell rod holder-83&84, selector part-85 on the mainframe
- 2 Fix the leg curl frame-86 on selector part-85 use T pin-183

## ASSEMBLY STEP 12

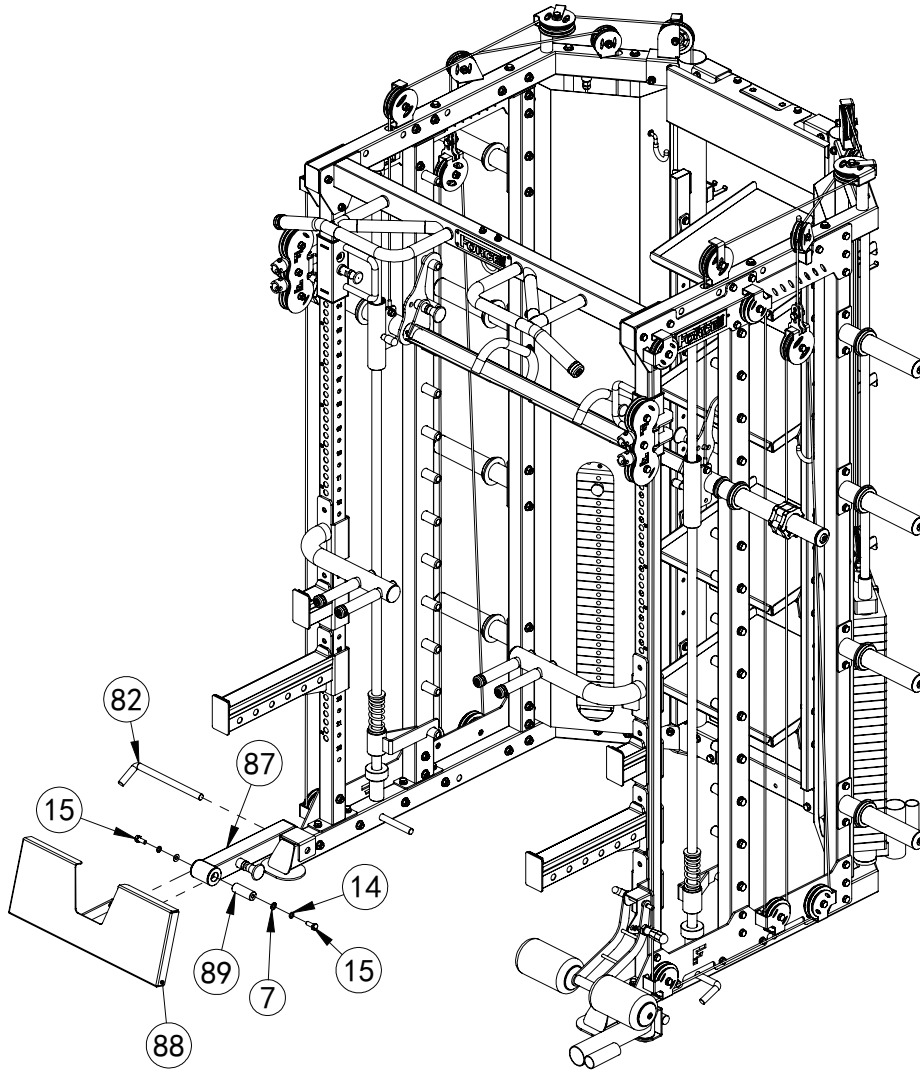

No.	Description	Note	Qty.
82	L shape pin	Φ17x250x77L	1
87	link frame		1
88	footplate		1
89	internal thread shaft	Φ25x67-M10	1
15	hexagon bolt	M10x25	2
14	spring washer	Φ10	6
7	washer	Φ10	10

# ASSEMBLY DRAWING

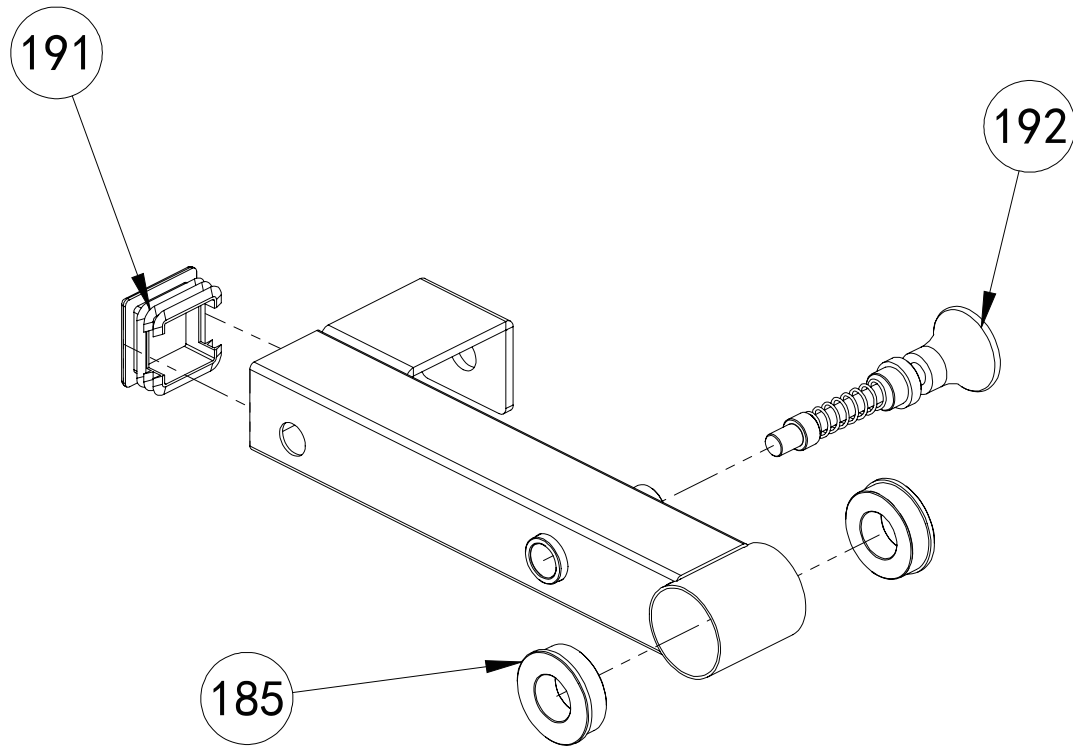

footplate  
1pcs/set

No.	Description	Note	Qty.
191	plug	□50x50x2	1
192	pin	Φ12xM20x75	1
185	sleeve	Φ50xΦ47xΦ25x15	2

# ASSEMBLY DRAWING

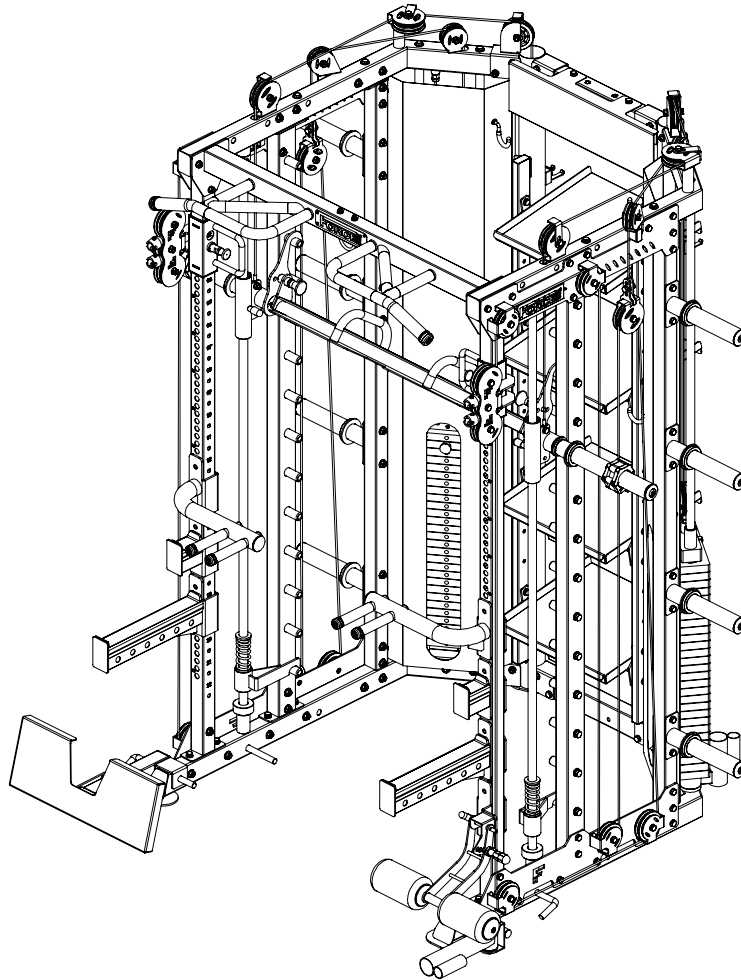

- 1 Connect link frame-87 and footplate-88 use M10x25 hexagon bolt-15,  $\Phi$ 10 washer-7,  $\Phi$ 10 spring washer-14 and  $\Phi$ 25x67-M10 shaft-89  
Attach them to the mainframe use L shape pin-82



# ASSEMBLY STEP 13

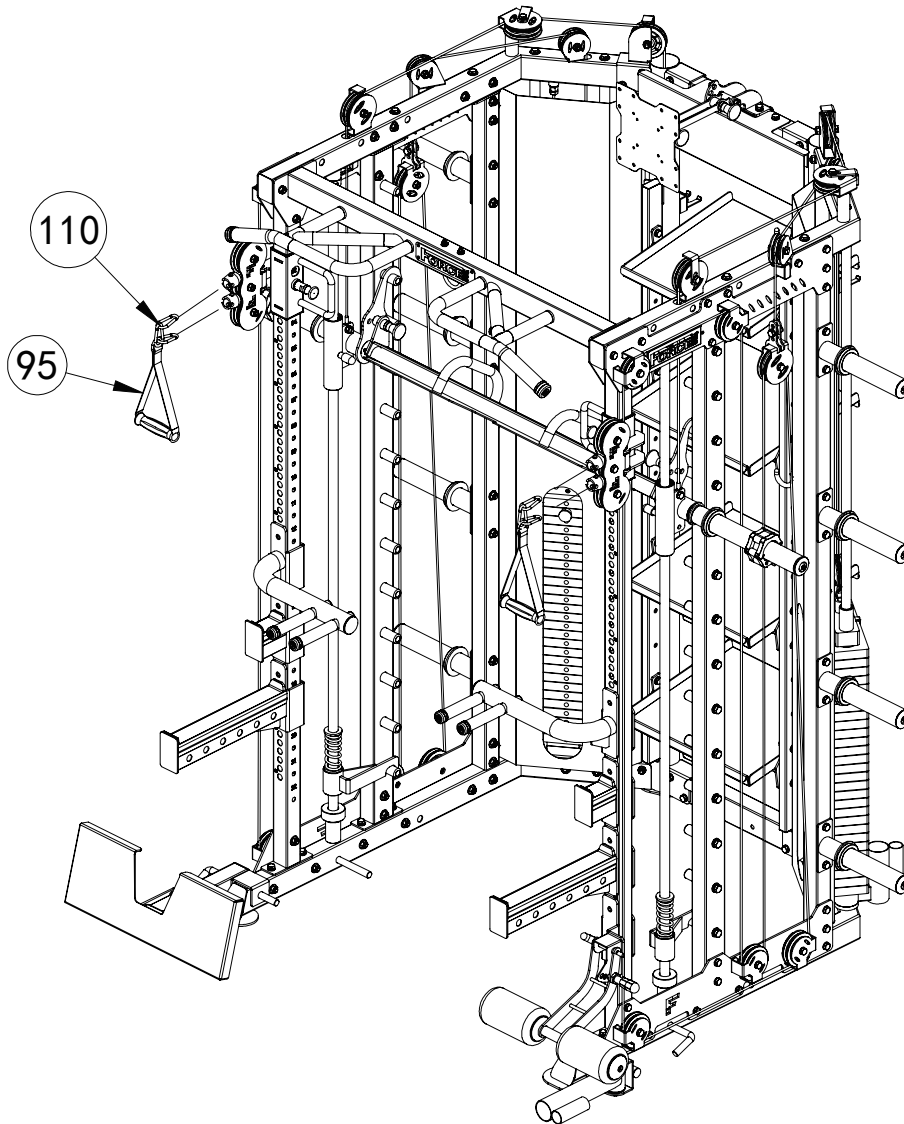

No.	Description	Note	Qty.
95	hand hold		2
110	snap hook		6

# ASSEMBLY DRAWING

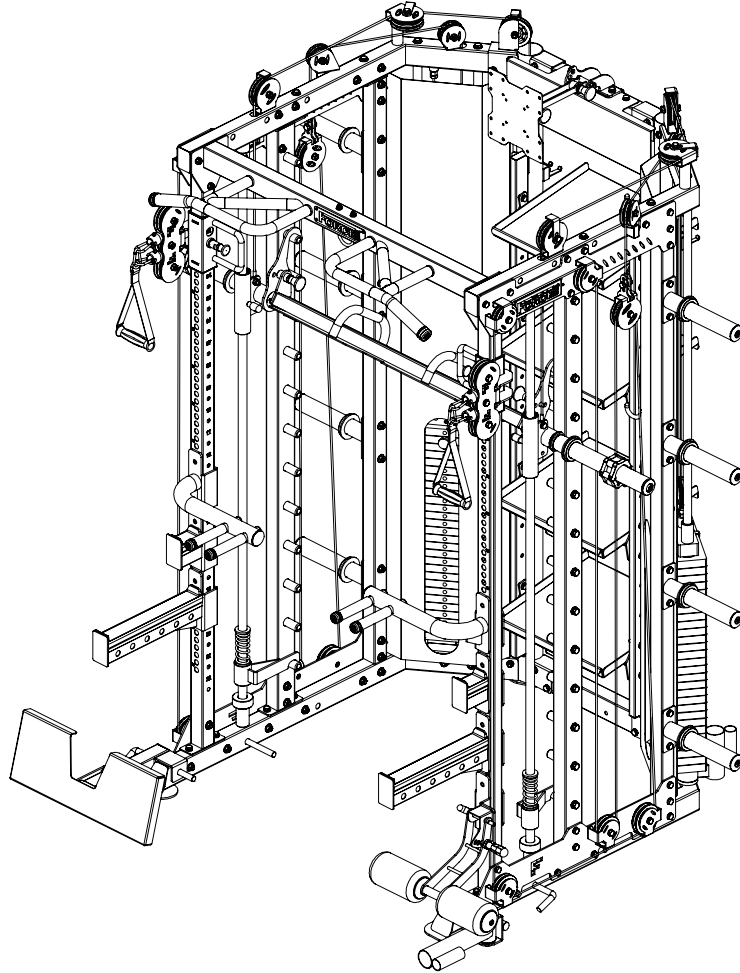

1 Connect hand hold-95 on the mainframe use snap hook-110

# SPARE PART

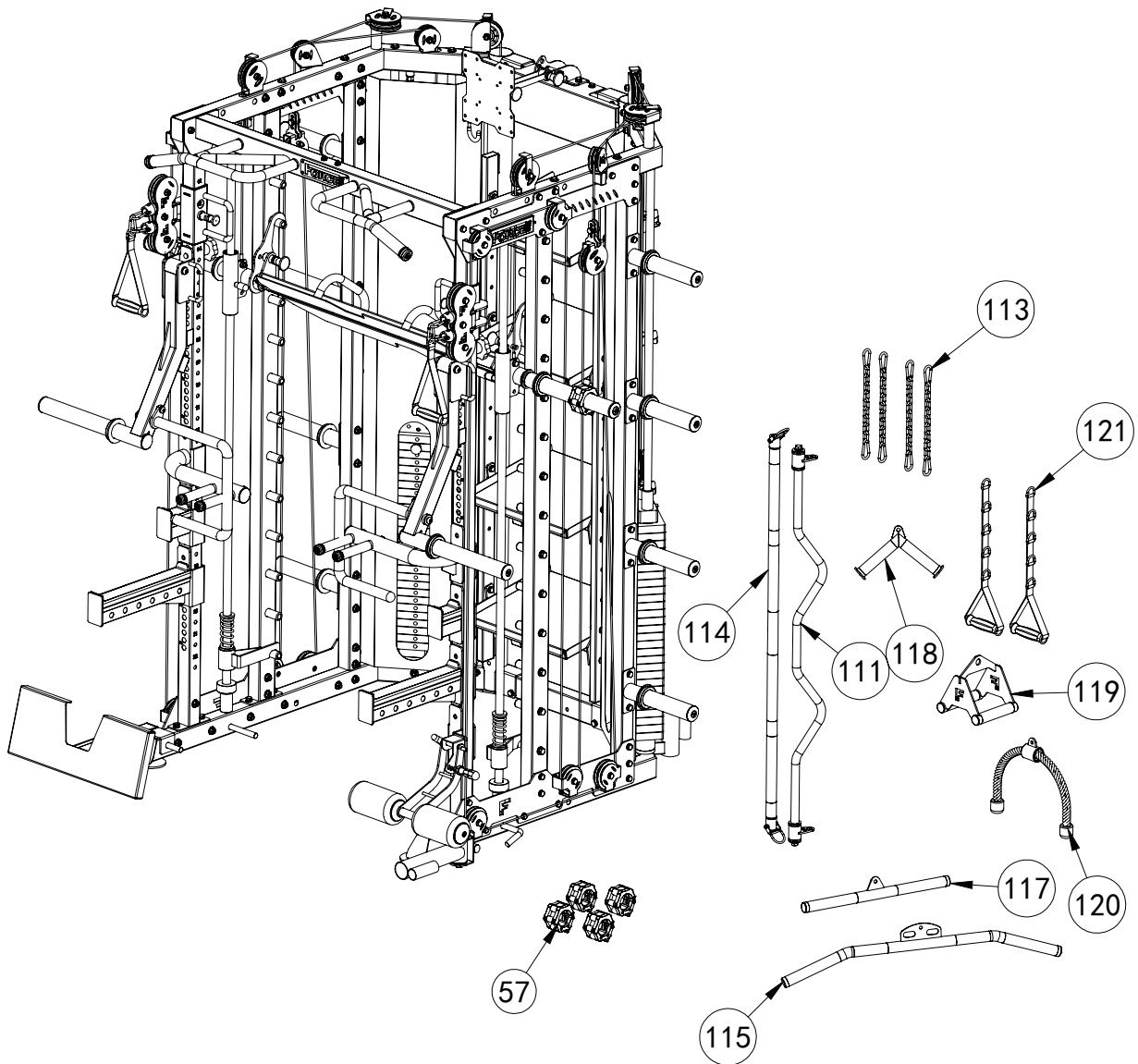

No.	Description	Note	Qty.
57	barbell rod collar	Φ85xΦ50xH49	4
111	curved bar		1
113	snap hook with chain		4
114	ship bar		1
115	long bar		1
117	short bar		1
118	V bar		1
119	triangle handle		1
120	triceps rope		1
121	handle belt		2

# UPGRADE KIT DRAWING

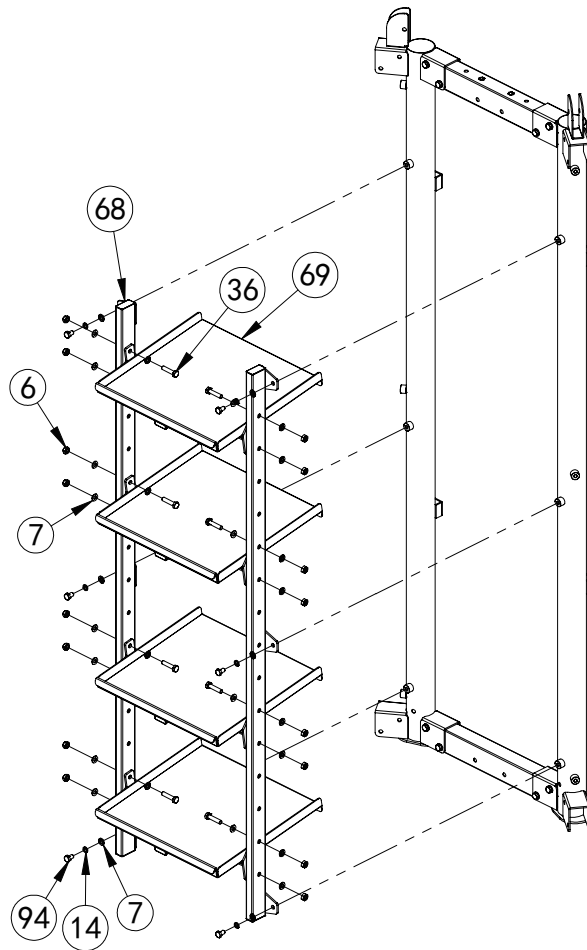

No.	Description	Note	Qty.
68	shelf frame		2
69	shelf		4
36	hexagon bolt	M10x45	16
7	washer	Φ10	38
6	lock nut	M10	16
14	spring washer	Φ10	6
94	hexagon bolt	M10x20	6

# UPGRADE KIT DRAWING

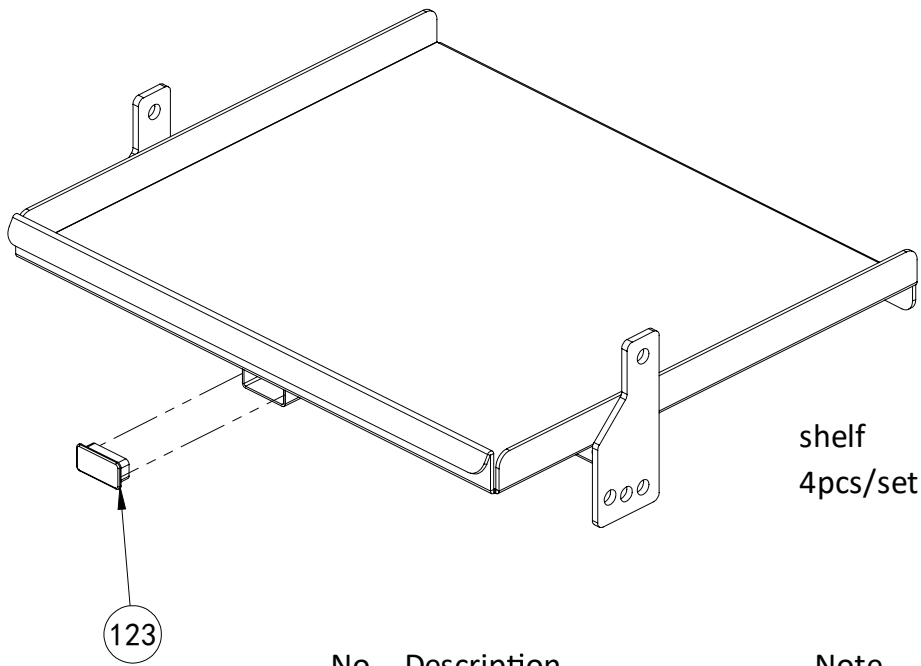

No.	Description	Note	Qty.
123	plug	□40x20x1.5	1

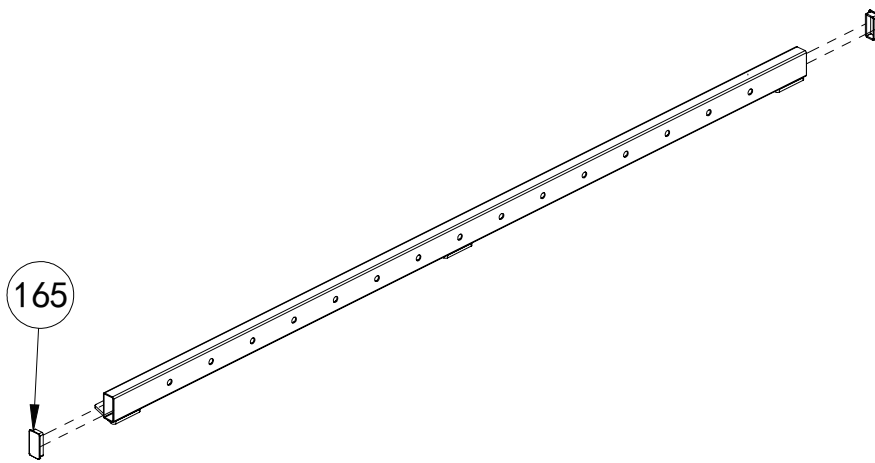

No.	Description	Note	Qty.
165	plug	□25x50x1.5	2

# UPGRADE KIT DRAWING

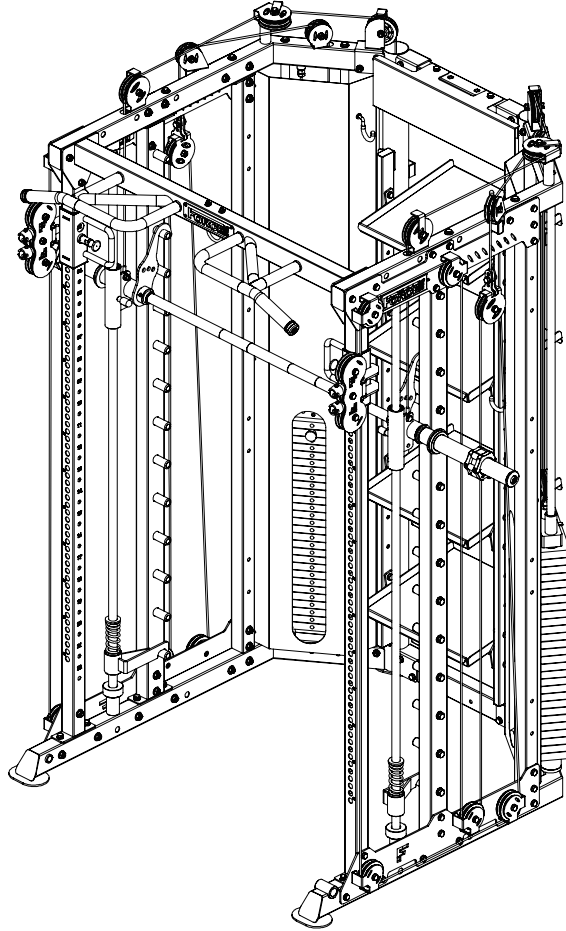

- 1 Attach shelf frame-68 on the mainframe use M10x20 hexagon bolt-94,  $\Phi$ 10 washer-7,  $\Phi$ 10 spring washer-14
- 2 Attach shelf-69 to shelf frame-68 use M10x45 hexagon bolt-36,  $\Phi$ 10 washer-7 and M10 lock nut-6

# UPGRADE KIT DRAWING

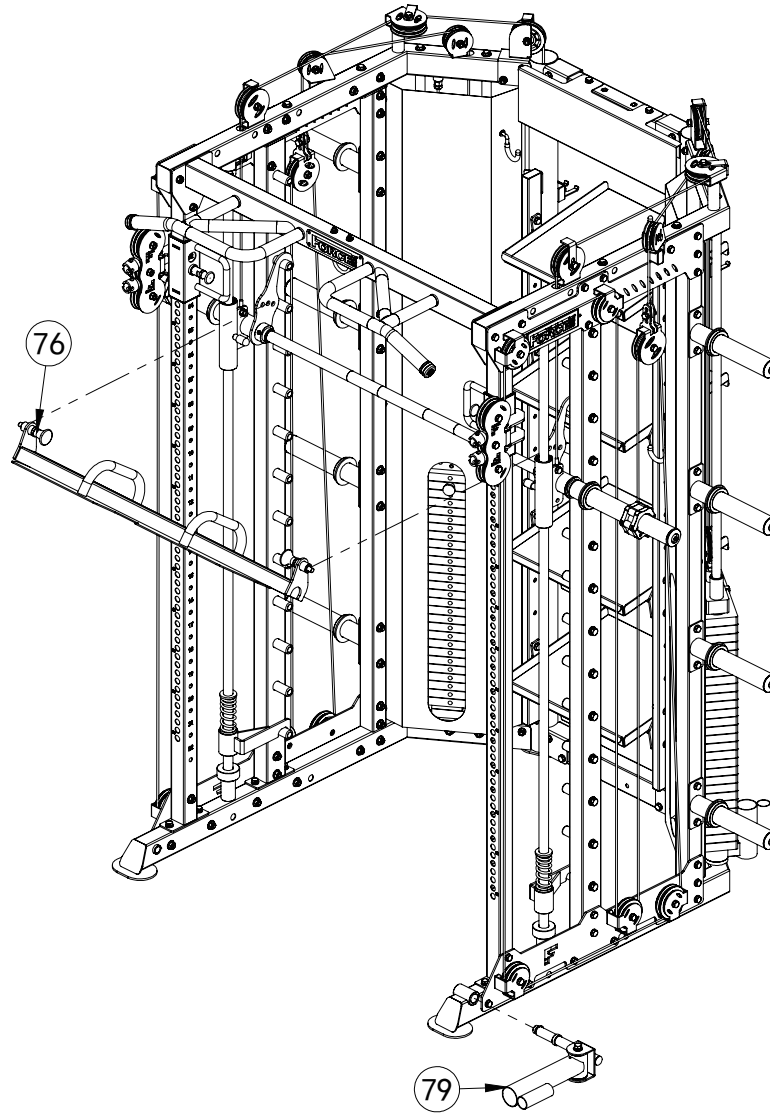

No.	Description	Note	Qty.
76	leg press plate		1
79	spinning barbell rod cup		1

# UPGRADE KIT DRAWING

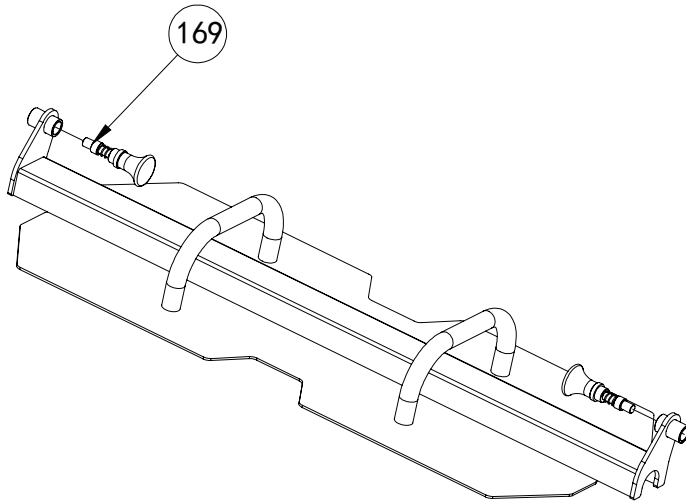

leg press plate  
1pcs/set

No.	Description	Note	Qty.
169	pin	Φ12xM20x40	2

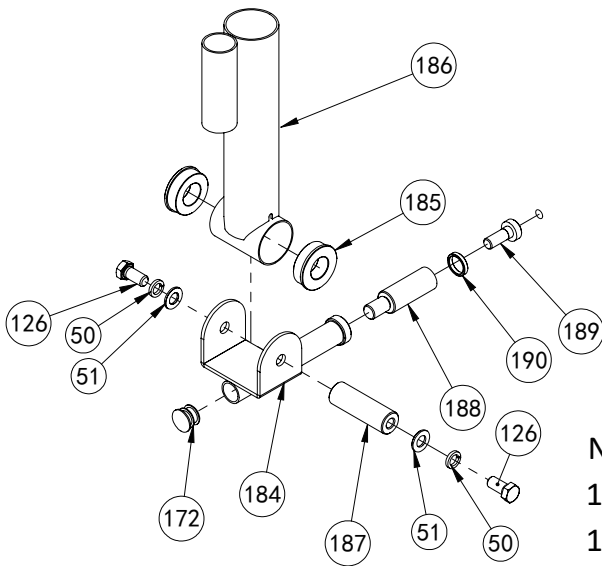

spinning barbell rod cup  
1pcs/set

No.	Description	Note	Qty.
184	link part		1
185	sleeve	Φ50xΦ47xΦ25x15	2
126	hexagon bolt	M12x25	2
172	plug	Φ25x2	1
51	washer	Φ12	2
186	barbell rod cup		1
187	internal thread shaft	Φ25x77xM12	1
188	tube	Φ25x86	1
189	shaft	Φ22x39.5	1
190	ring	Φ25xΦ20x5	1
50	spring washer	Φ12	2



# UPGRADE KIT DRAWING

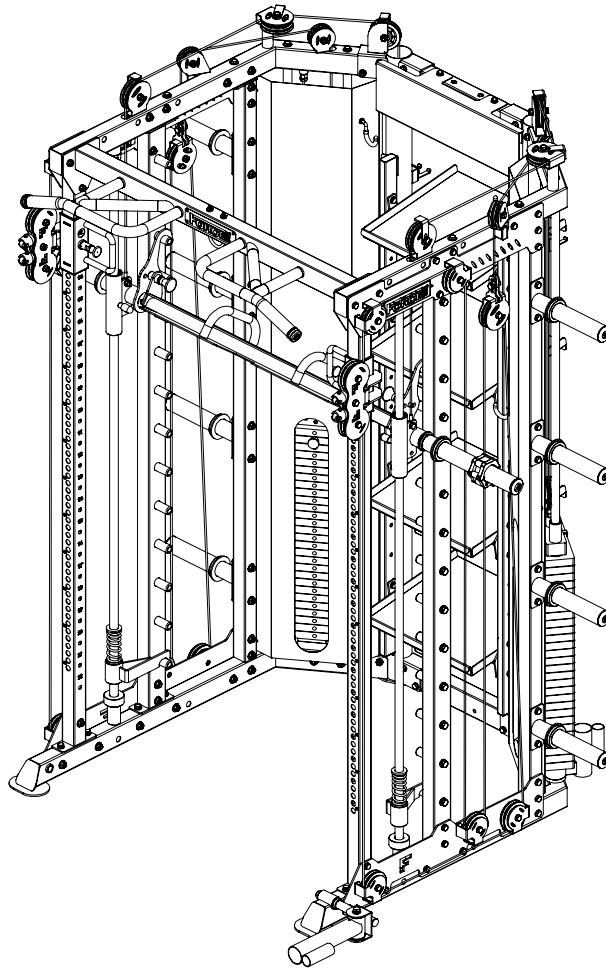

1 Put leg press plate-76,spinning barbell rod cup-79 on the mainframe

# UPGRADE KIT DRAWING

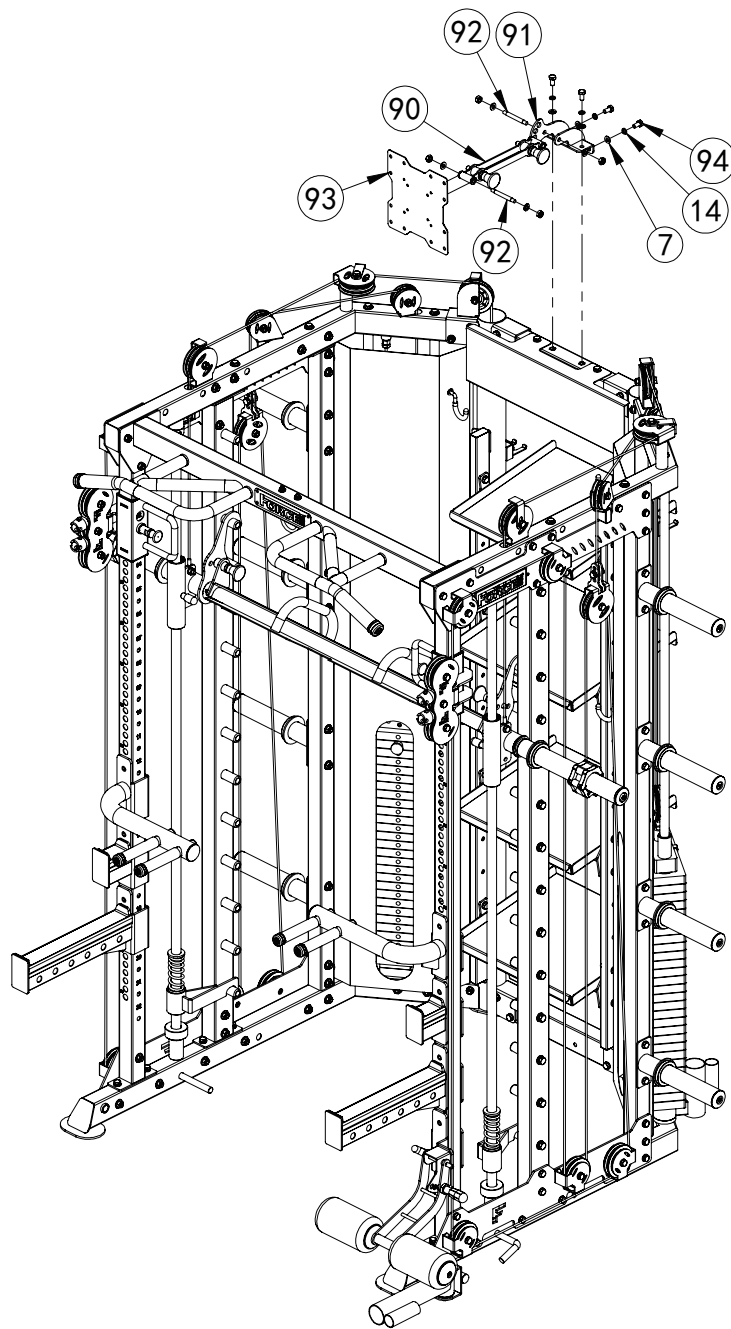

No.	Description	Note	Qty.
14	spring washer	Φ10	6
7	washer	Φ10	10
90	link frame		1
91	selector frame		1
92	shaft	Φ10x85xM10	2
6	lock nut	M10	4
93	TV bracket		1
94	hexagon bolt	M10x20	4

# UPGRADE KIT DRAWING

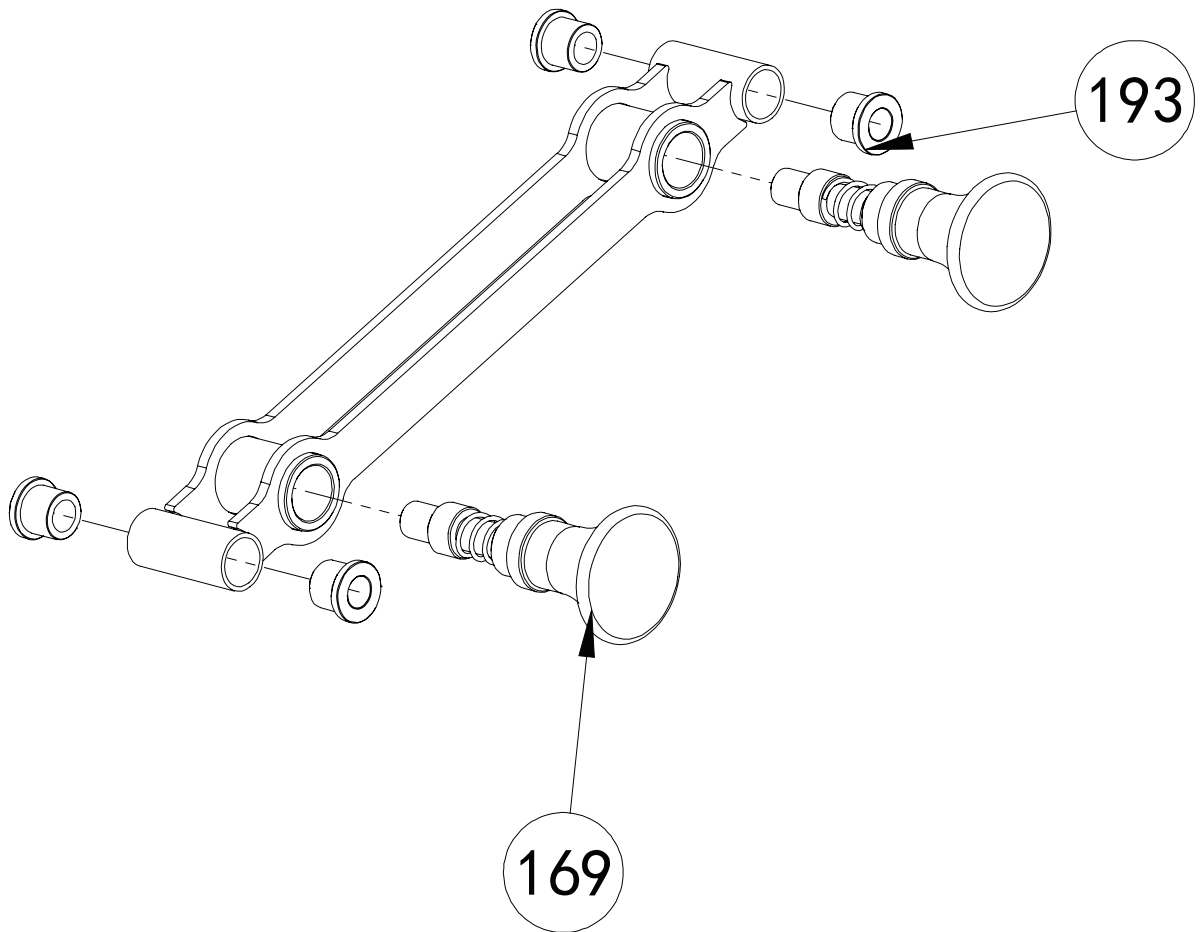

link frame  
1pcs/set

No.	Description	Note	Qty.
193	sleeve	$\Phi 20 \times \Phi 16 \times \Phi 10.5 \times 15$	4
169	pin	$\Phi 12 \times M20 \times 40$	2

# UPGRADE KIT DRAWING

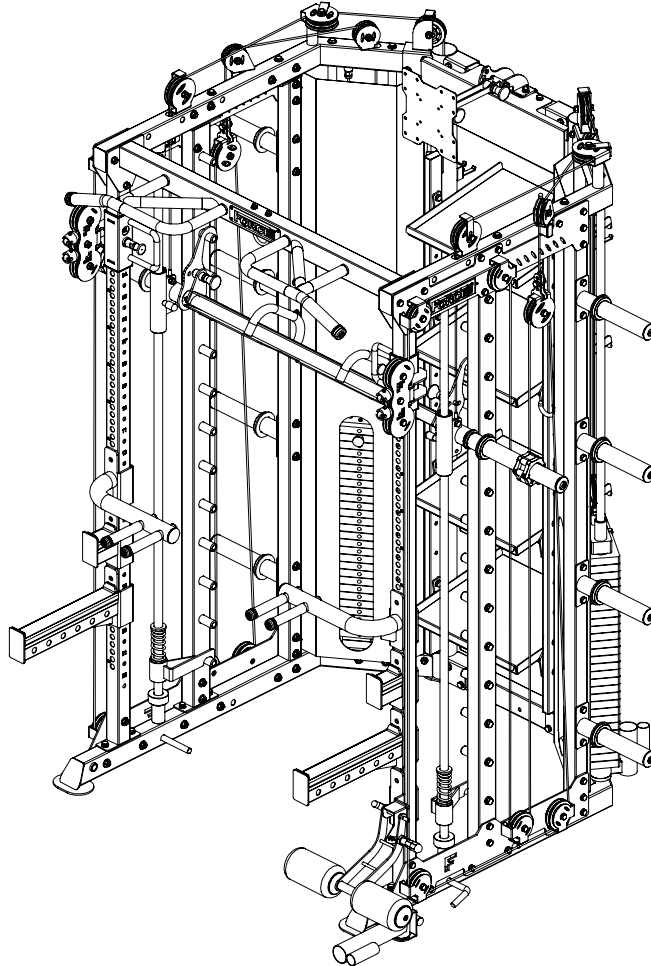

2 Connect link frame-90, selector frame-91, TV bracket-93 use  $\Phi 10 \times 85 \times M10$  shaft-92,  $\Phi 10$  washer-7, M10 lock nut-6  
Attach them to the mainframe use M10x20 hexagon bolt-94,  $\Phi 10$  washer-7,  $\Phi 10$  spring washer-14

# UPGRADE KIT DRAWING

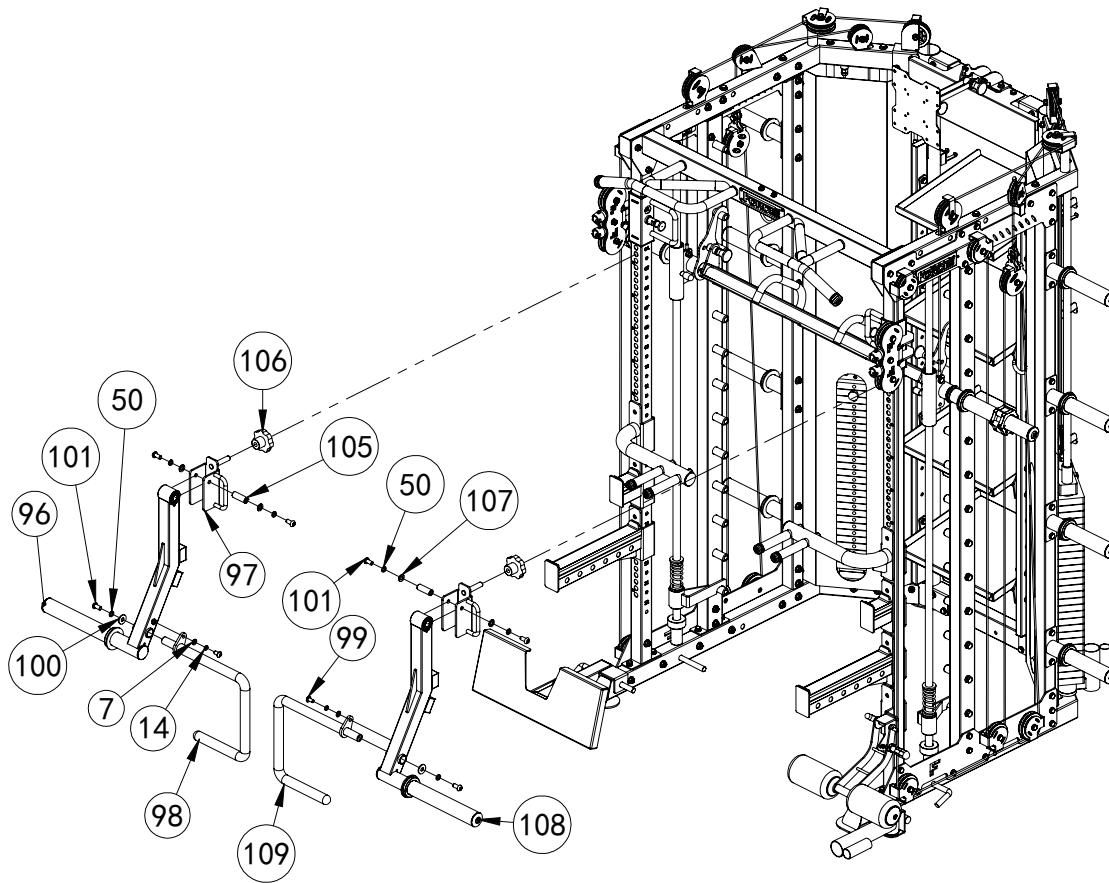

No.	Description	Note	Qty.
96	push frame left		1
97	link part		2
98	handle left		1
99	allen bolt	M10x20	2
7	washer	Φ10	2
100	washer	Φ33xΦ12.5xT3	2
101	allen bolt	M12x25	6
50	spring washer	Φ12	6
14	spring washer	Φ10	2
105	internal thread shaft	Φ20x56.5-M12	2
106	lock knob	M16	2
51	washer	Φ12	4
108	push arm right		1
109	handle right		1

# UPGRADE KIT DRAWING

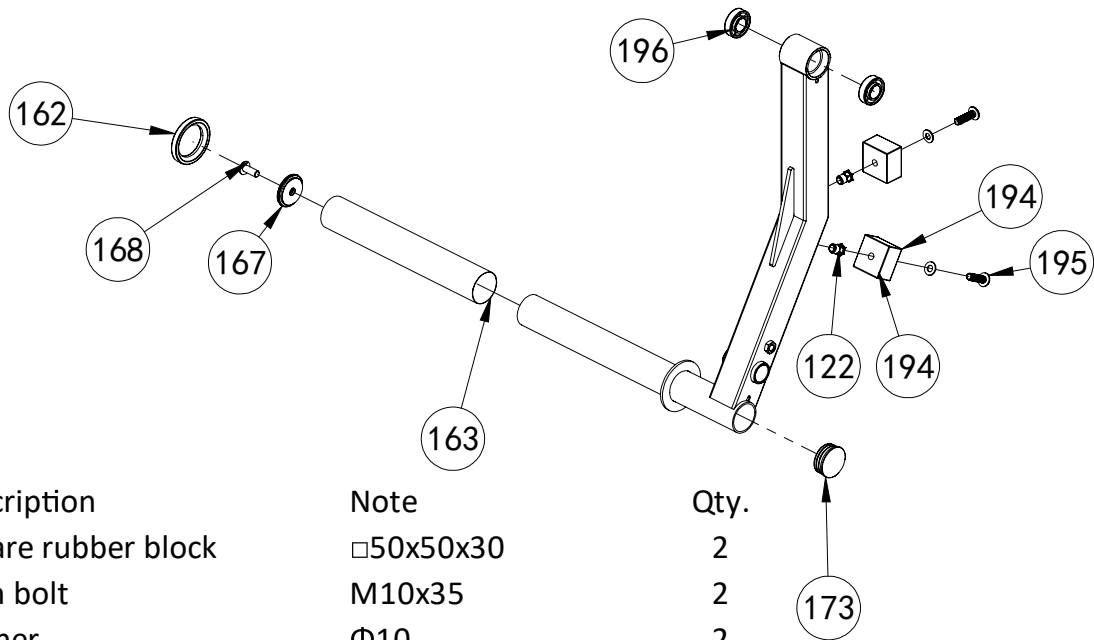

No.	Description	Note	Qty.	
194	square rubber block	□50x50x30	2	
195	allen bolt	M10x35	2	
7	washer	Φ10	2	
162	rubber ring	Φ70xΦ50xΦ10	1	
163	tube	Φ49.5x0.6	1	
196	6004bearing		2	
122	lock nut	M10	2	
173	plug	Φ48x2.5	1	push arm right&left
167	end cap	Φ11xΦ18xΦ42xΦ50	1	1pcs/set
168	allen bolt	M10x25	1	

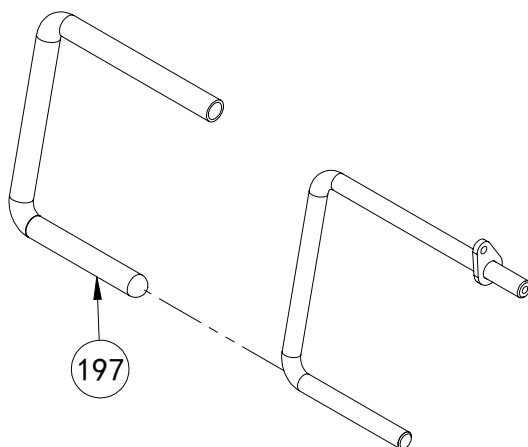

handle right&left  
1pcs/set

No.	Description	Note	Qty.
197	handle cover	Φ32xΦ24.8x830	1

# UPGRADE KIT DRAWING

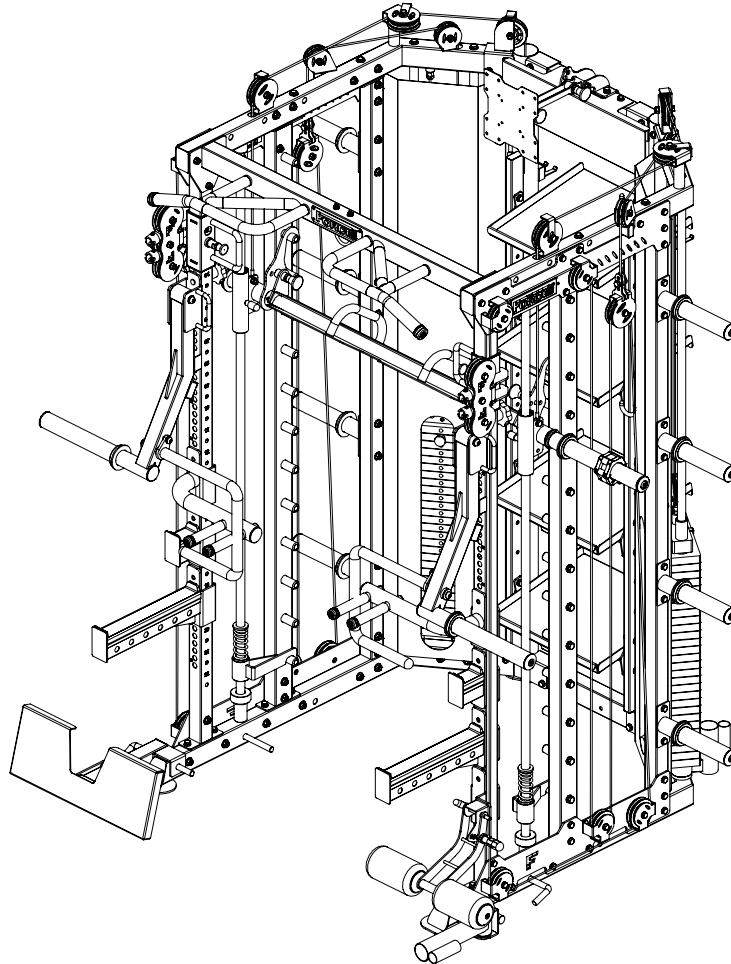

- 1 Connect link part-97, push frame left-96 and push arm right-108 use M12x25 hexagon bolt-101,  $\Phi$ 12 washer-51,  $\Phi$ 12 spring washer-50 and  $\Phi$ 20x56.5-M12 shaft-105  
Attach them on the mainframe use M16 lock knob-106
- 2 Connect handle left-98, handle right-109 and push arm use M10x20 allen bolt-99,  $\Phi$  10 washer-7,  $\Phi$ 10 spring washer-14, M12x25 allen bolt-101,  $\Phi$ 12 spring washer-50,  $\Phi$  33x $\Phi$ 12.5xT3 washer-100

# UPGRADE KIT DRAWING

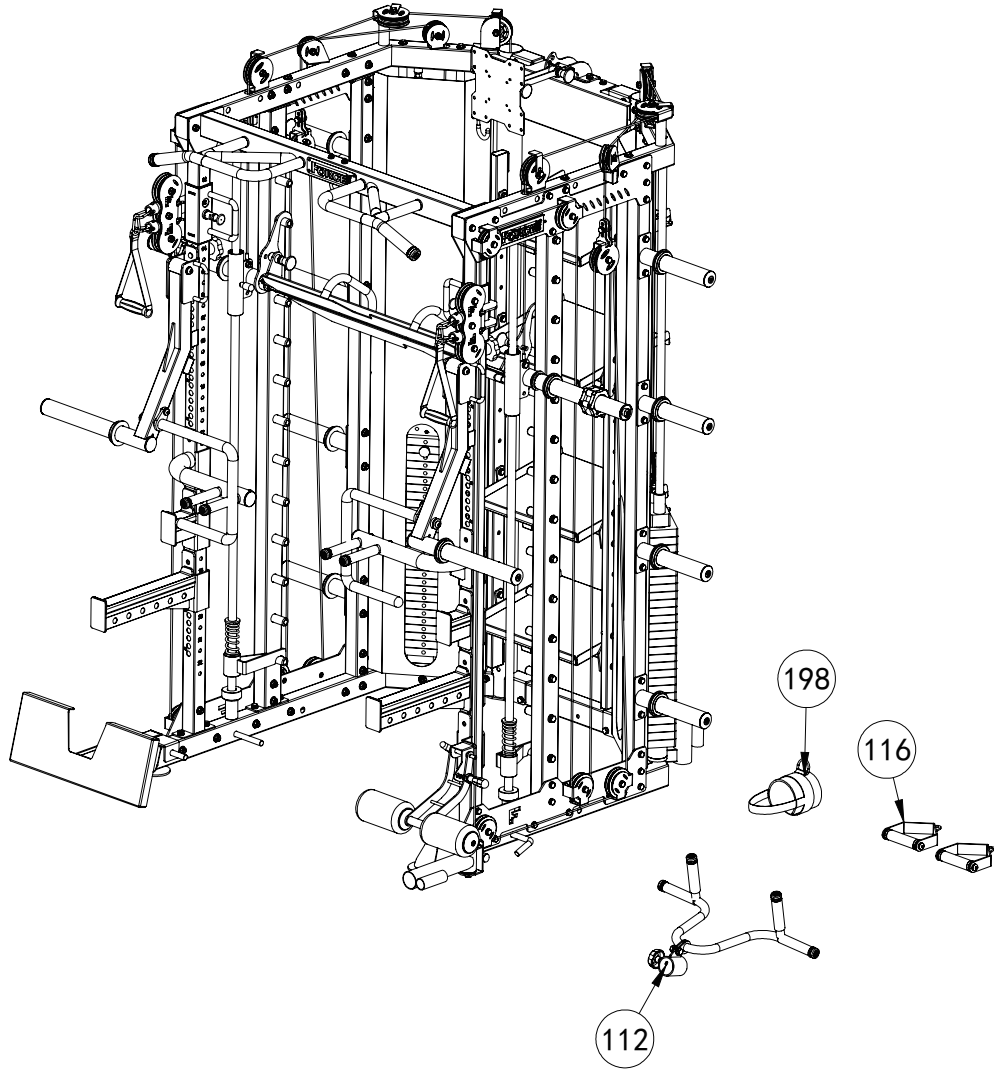

No.	Description	Note	Qty.
112	lift device		1
116	handle		2
203	ankle strap		1





Success doesn't come from sitting on your ass. Success comes from striving to be better than yesterday. It comes from the urge to push boundaries and break through barriers. We know this because we've been there from selling the first piece of Force USA gear in 2007 to providing commercial and home gym equipment all over the globe. We are for helping you become your strongest self. **We are for innovation in strength.**

## **WARRANTY**

### LIFETIME WARRANTY ON FRAME - 2 YEAR WARRANTY ON MOVING PARTS

The Force USA range of strength equipment carries a Lifetime Structural Warranty along with two years cover on all cables and pulleys. This warranty applies to first owners and does not cover second-hand equipment or re-sold equipment. This Force USA warranty covers only failures due to defects in structural, cables and pulleys and workmanship that occur during regular home use. It will not cover damage that occurs in transport/delivery or failure due to misuse, abuse, neglect, misapplication, alteration or improper assembly of the product. This warranty does not cover the use or failure of equipment in-studio commercial applications. The replacement or repair provided for under the Force USA warranty is the responsibility of the user, and the customer will be responsible for any freight charges that apply. Force USA will not be liable for any consequential damages or breach of any implied warranty on the range of Force USA strength equipment. Force USA reserves the right to provide reconditioned parts and/or to request a return and repair existing defective components on the Force USA product.

Force USA uses commercial-grade upholstery for all Force USA strength equipment. The commercial vinyl comes with a rip-stop mesh backing to help prevent rips and tears.

[WWW.FORCEUSA.COM](http://WWW.FORCEUSA.COM)

